

WG222 Dual-Band Wi-Fi and Bluetooth Combo Module Datasheet

Document Information

Title WG222 Dual-Band Wi-Fi and Bluetooth Combo Module Datasheet

Document type Datasheet

Document number SL-18020007

Revision and date V1.08 11-Mar -2019

Disclosure restriction Public

This document applicable to the following products:

Product name	Type number	Product status
WG222	WG222E(09289)	Mass production
	WG222P(0928901)	Mass production

SKYLAB reserves all rights to this document and the information contained herein. Products, names, logos and designs described herein may in whole or in part be subject to intellectual property rights. Reproduction, use, modification or disclosure to third parties of this document or any part thereof without the express permission of SKYLAB is strictly prohibited.

The information contained herein is provided “as is” and SKYLAB assumes no liability for the use of the information. No warranty, either express or implied, is given, including but not limited, with respect to the accuracy, correctness, reliability and fitness for a particular purpose of the information. This document may be revised by SKYLAB at any time. For most recent documents, visit www.skylab.com.cn.

Copyright © 2018, Skylab M&C Technology Co., Ltd.

SKYLAB® is a registered trademark of Skylab M&C Technology Co., Ltd in China

Contents

Contents	3
1 General Description.....	4
2 Features.....	4
■General.....	4
■Wi-Fi	5
■Buletooth	5
3 Applications	5
4 Module Block Diagram	6
5 Module Pinout and Pin Description	6
Module Pinout	6
Pin Description	7
6 Dimensions.....	10
7 Electrical Characteristics	10
8 Performance Specification	12
9 Reference Schematic of Evaluation Board	14
10 Manufacturing Process Recommendations	19
11 Ordering Information.....	20
12 Contact Information	21

1 General Description

WG222 is a highly integrated WiFi/BLE combo module which features an application processor, a low power 1x1 802.11n dual-band Wi-Fi subsystem, a Bluetooth subsystem, and a Power Management Unit. The application processor subsystem contains an ARM Cortex-M4F MCU. It also includes many peripherals, including UART, I2C, SPI, I2S, PWM, IrDA, and auxiliary ADC. It also includes embedded SRAM/ROM. The Wi-Fi subsystem contains the 802.11a/b/g/n radio, baseband, and MAC that are designed to meet both the low power and high throughput application. It also contains a 32-bit RISC CPU that could fully offload the application processor. The Bluetooth subsystem contains the Bluetooth radio, baseband, link controller. It also uses the same 32-bit RISC CPU for the Bluetooth protocols. The module requiring only an external 3.3V power supply. Below is the module top view.



Figure 1: WG222 Top View

2 Features

■ General

- ◆ ARM Cortex-M4 MCU with FPU with up to 192MHz clock speed
- ◆ 22 General Purpose IOs multiplexed with other interfaces
- ◆ Two UART interfaces with hardware flow control and one UART for debug, all multiplexed with GPIO
- ◆ One SPI master or SPI slave interface multiplexed with GPIO
- ◆ One I2C master interface multiplexed with GPIO
- ◆ One I2S interface multiplexed with GPIO
- ◆ Four channels 12-bit ADC multiplexed with GPIO
- ◆ 22 PWM multiplexed with GPIO
- ◆ Module Size: 31.3mm*20.3mm*3.2mm

- ◆ Voltage supply: 3.3V±10%

■ Wi-Fi

- ◆ 802.11 a/b/g/n
- ◆ Supports 20MHz, 40MHz bandwidth in 2.4GHz band 5GHz band
- ◆ Dual-band 1T1R mode with data rate up to 150Mbps
- ◆ Automatic Beacon monitoring/scanning
- ◆ 802.11 i security features: pre-authentication and TSN; Hardware crypto engines including AES, DES/3DES, SHA2 for network security
- ◆ Infrastructure BSS Station mode/SoftAP mode

■ Bluetooth

- ◆ Compliant with Bluetooth v4.2 BLE specification
- ◆ Enhanced power control
- ◆ Maximum +10 dBm transmitting power
- ◆ BLE Beacon
- ◆ Security Manage Protocol (SMP)

3 Applications

- ◆ BLE beacon
- ◆ Industrial wireless control
- ◆ Bluetooth gateway
- ◆ Wearable electrical devices
- ◆ Wi-Fi location-aware devices
- ◆ Security ID tags
- ◆ Smart home

4 Module Block Diagram

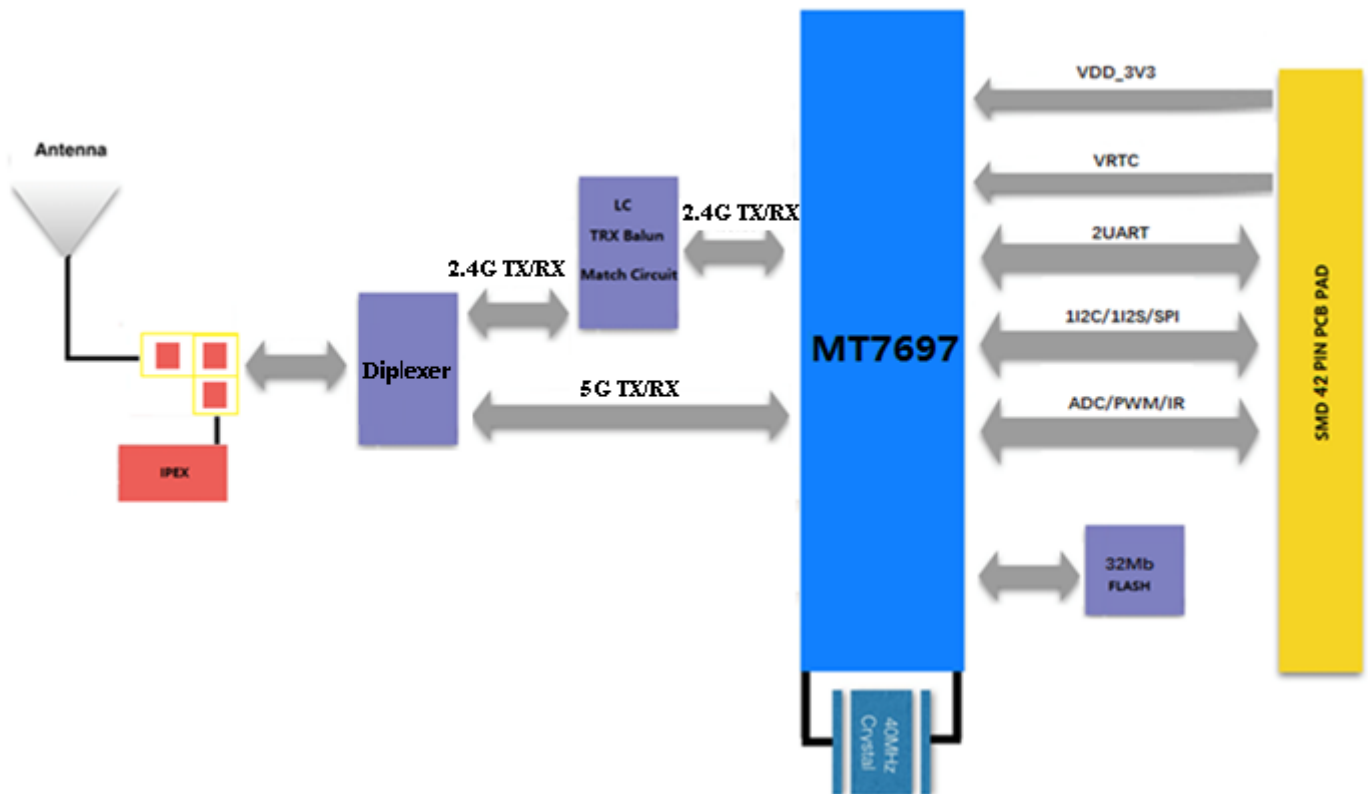

Figure 2: WG222 Block Diagram

5 Module Pinout and Pin Description

Module Pinout

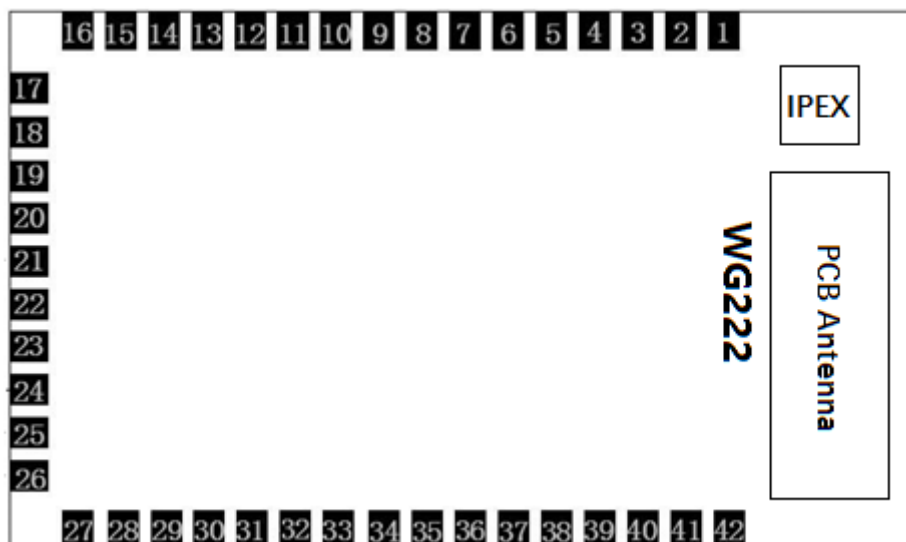

Figure 3: WG222 Pin Package

Pin Description

Pin No.	Pin Name	Description	Remark
1	GND	Ground	
2	GND	Ground	
3	UART0_RX	UART0 Data Input to Module/PWM23	GPIO2
4	UART0_TX	UART0 Data Output from Module/PWM24	GPIO3
5	SPI_DATA0_FLASH	NC	GPIO4
6	SPI_DATA1_FLASH	NC	GPIO5
7	SPI_CS1	SPI Chip Set1/PWM4	GPIO6
8	UART0_RTS	UART0 Request to Send/PWM0	GPIO0
9	UART0_CTS	UART0 Clear to Send/PWM1	GPIO1
10	GND	Ground	
11	SPI_CS0_FLASH	NC	GPIO7
12	SPI_MOSI_FLASH	NC	GPIO24
13	SPI_MISO_FLASH	NC	GPIO25
14	SPI_CLK_FLASH	NC	GPIO26
15	I2C0_CLK	I2C Clock/PWM28	GPIO27
16	VDD	Power Supply: 2.97-3.63V@300mA	
17	GND	Ground	
18	RTC_3V3	RTC Power Supply: 1.6-3.63V	
19	PWR_EN_RTC_OUT	Enable Module VDD Power in RTC Mode	
20	I2C0_DATA	I2C Data/PWM29	GPIO28
21	I2S_MCLK/SPI_MOSI	I2S MCLK/SPI MOSI/PWM30	GPIO29
22	I2S_FS/SPI_MISO	I2S FS/SPI MISO/PWM31	GPIO30
23	I2S_M_TX/I2S_S_RX/SPI_SCK	I2S Master TX/I2S Slave RX/SPI SCK/PWM32	GPIO31
24	I2S_BCLK/SPI_CS_0	I2S BCLK/SPI CS/PWM33	GPIO32

25	PMU_EN_WF_IN	In RTC mode. Don't support RTC interrupt, please tie PMU_EN_WF_IN to GND.	
26	GND	Ground	
27	VDD	Power Supply: 2.97-3.63V@300mA	
28	GND	Ground	
29	ADC3/MISC_LED_OUT	ADC Input/LED Output/PCM_IN/PWM39	GPIO60
30	ADC2/WF_LED_OUT	ADC Input/WIFI LED Output/PCM_OUT/PWM38	GPIO59
31	ADC1	ADC Input/PCM_CYNC/PWM37	GPIO58
32	ADC0	ADC Input/PCM_CLK/PWM36	GPIO57
33	UART1_CTS/MISC_LED_OUT	UART1 CTS/LED Output/PWM22	GPIO39
34	RESET	External System Reset, Active Low	
35	UART1_RX	UART1 Data Input to Module/PWM19	GPIO36
36	UART1_TX	UART1 Data Output from Module/PWM20	GPIO37
37	GND	Ground	
38	UART1_RTSS/WF_LED	UART1 RTS/LED Output/PWM21	GPIO38
39	GPIO	GPIO35/PWM18	GPIO35
40	IR_RX/MISC_LED_OUT	IrDA RX/LED Output/PWM35	GPIO34
41	IR_TX/WF_LED	IrDA TX/LED Output/PWM34	GPIO33
42	GND	Ground	

Note: the red character indicates that GPIO is associated with Bootstrap. Use it carefully.

Bootstrap

The section describes the bootstrap function.

The chip modes are sensed from the device pin during power up. After chip reset, the pull configuration is stored in a register and determine the device operation mode.

Bootstrap Option– Flash Access Mode

Flash Access Mode	(GPIO37)	Description
Normal mode	Pull-down	Firmware jumps to Flash
Recovery mode	Pull-up	Firmware does not jump to flash and wait for UART command; This mode is used for the firmware to jump to SYSRAM after downloading code from UART

Bootstrap Option– Module mode

Function	Pin	Sub-function	Pin	Read-only CR	Value	Description
Normal mode XTEST=0	GPIO35=0	bt_host_sel(when SIP_MODE=0) Flash mode(when SIP_MODE=1)	GPIO37	0 x 80021010 【5】	0	Flash normal mode
					1	Flash recovery mode
		Rtc_mode/external 32 KHz	GPIO6	0 x 80021010 【31】	0	ext 32KHz clock disable
					1	ext 32KHz clock enable
		Xtal_freq 【1:0】	{ GPIO7, GPIO38}	0 x 80021010 【14:13】	00	NA
					01	40 MHz
					10	26MHz
11	52 MHz					
Test mode	GPIO35=1					

Note: the item shown in the red character is the module default configuration.

6 Dimensions

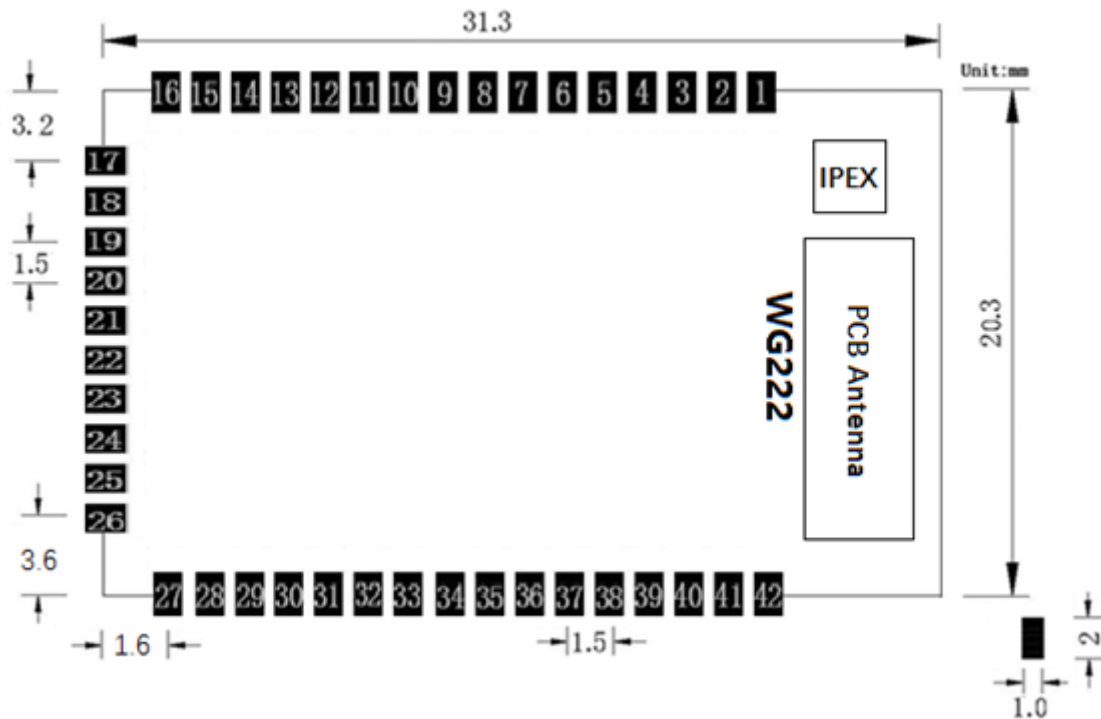

Figure 4: WG222 Dimensions

7 Electrical Characteristics

a) Absolute Maximum Ratings

Parameter	Condition	Min.	Typ.	Max.	Unit
Storage Temperature Range		-40		125	°C
ESD Protection	VESD	/		2000	V
Supply Voltage	VCC	0		3.63	V
Voltage On Any I/O Pin		-0.3		3.63	V

Table7-1: Absolute Maximum Ratings

WG222 series modules are Electrostatic Sensitive Devices and require special precautions while handling.



ESD precautions

The WG222 module contain highly sensitive electronic circuitry and are Electrostatic Sensitive Devices (ESD). Handling the WG222 module without proper ESD protection may destroy or damage them permanently.

The WG222 module are electrostatic sensitive devices (ESD) and require special ESD precautions typically applied to ESD sensitive components. Proper ESD handling and packaging procedures must be applied throughout the processing, handling, transportation and operation of any application that incorporates the WG222 module. Don't touch the module by hand or solder with non-anti-static soldering iron to avoid damage to the module.

b) Recommended Operation Ratings

Parameter	Symbol	Min	Typ.	Max.	Unit
Operating Temperature Range	TA	-20		70	°C
Power Supply	VCC	2.97	3.3	3.63	V

Table7-2: Operating Conditions

c) Power Consumption

System State	Current (Typ.)@3.3V	Current (Max.)@3.3V
Standby	3.9 mA	
SLEEP(VRTC)	10uA	
Transmit (2.4g; +16 dBm @ TX HT20 MCS7.)	62 mA	
Transmit (2.4g; +20 dBm @ 11b 11Mbps.)	75mA	210mA

Table7-3: Power Consumption in Different States

D) Auxiliary ADC Characteristics

Symbol	Parameter	Min	Typical	Max	Unit
N	Resolution	-	12	-	Bit
FS	Sampling Rate @ N-Bit ⁽¹⁾	-	2	-	MSPS
VPP	Input Swing ⁽²⁾	-	-	1.8	V
VIN	Input voltage ⁽³⁾	0	-	1.8	V
RIN	Input Impedance: Unselected channel	400M	-	-	Ohm
	Selected channel	-	10K	-	
DNL	Differential Nonlinearity without dithering and averaging	-	± 1	± 2	LSB
INL	Integral Nonlinearity without dithering and averaging	-	± 2	± 4	LSB

Table7-4: Auxiliary ADC Specifications

8 Performance Specification

Hardware Features	
Model	WG222
Antenna Type	IPEX connect or PCB Antenna
Chipset solution	MT7697
Voltage	3.3V±10%
Dimension(LxWxH)	31.3mm*20.3mm*3.2mm
WIFI Wireless Features	
Wireless Standards	IEEE 802.11a/b/g/n
Frequency Range	2.412GHz-2.484GHz & 5.180GHz -5.825GHz
Data Rates	IEEE 802.11b : 1,2,5.5,11Mbps
	IEEE 802.11g : 6,9,12,18,24,36,48,54Mbps
	IEEE 802.11n : MCS0--MCS7 @ HT20 /2.4GHz band
	MCS0--MCS7 @ HT40 /2.4GHz band

	MCS0—MCS7 @ HT40 /5GHz band
Receiver Sensitivity	HT40 MCS7 : -70dBm@10% PER(MCS7) /5GHz band
	HT40 MCS7 : -70dBm@10% PER(MCS7) /2.4GHz band
	HT20 MCS7 : -73dBm@10% PER(MCS7) /2.4GHz band
	54M: -75dBm@10% PER
	11M: -88dBm@ 8% PER
Modulation Technique	DSSS (DBPSK, DQPSK, CCK)
	OFDM (BPSK, QPSK, 16-QAM, 64-QAM)
Wireless Security	WPA/WPA2, WEP, TKIP and AES, WPS2.0, WAPI
Transmit Power	IEEE 802.11n: 14-17dBm @HT20 MCS7 /5GHz band
	IEEE 802.11n: 14-17dBm @HT40 MCS7 /5GHz band
	IEEE 802.11n: 15-18dBm @HT20/40 MCS7 /2.4GHz band
	IEEE 802.11g: 15-18dBm @54Mbps
	IEEE 802.11b: 18-21dBm @11Mbps
Work Mode	AP, Station, AP/Client
Others	
Certification	RoHS compliance
Environment	Operating Temperature: -20°C~70°C
	Storage Temperature: -40°C~125°C
	Operating Humidity: 10%~90% non-condensing
	Storage Humidity: 5%~90% non-condensing

Bluetooth Wireless Features	
Wireless Standards	Bluetooth4.2 BLE
Frequency Range	2.402GHz -2.480GHz
Receive Sensitivity	BER<0.1%: -95dBm

Wireless Transmit Power	BLE: -20 dBm to +10dBm
-------------------------	------------------------

9 Reference Schematic of Evaluation Board

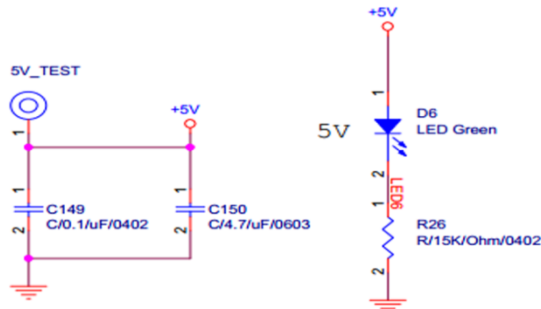

DC_DC_3V3

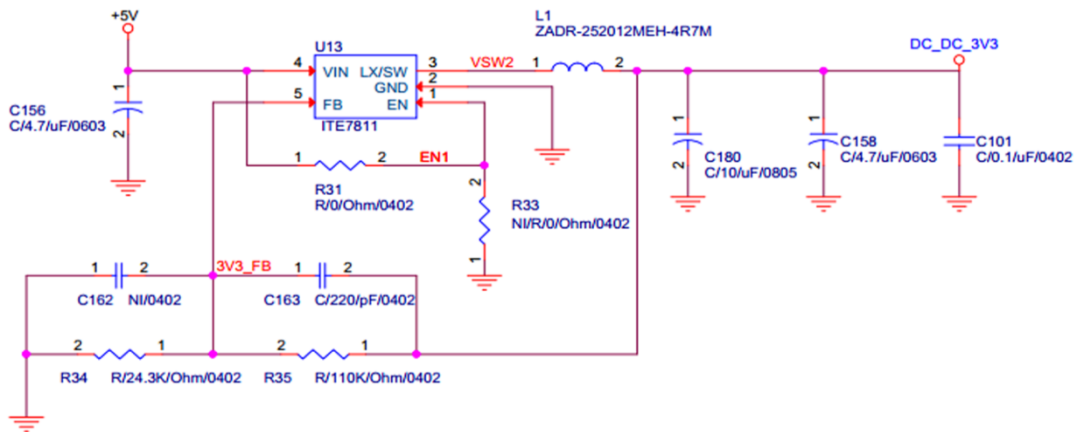

2xAA Battery

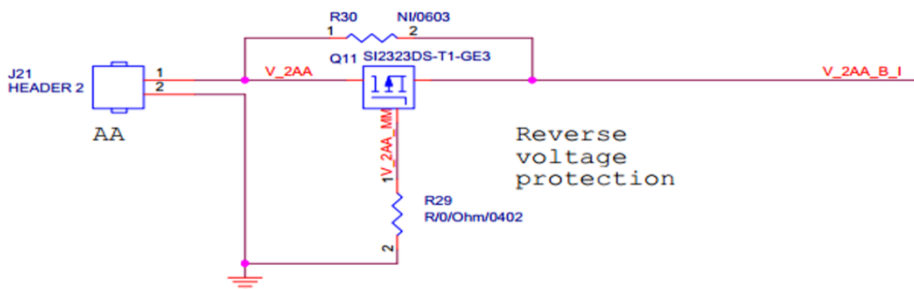

Reverse
voltage
protection

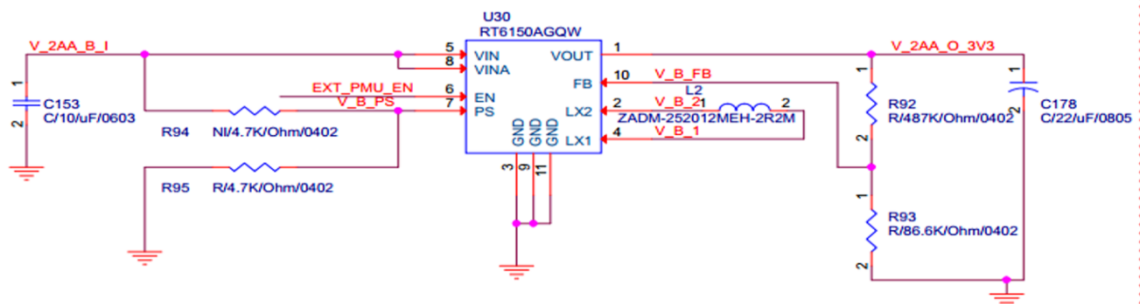

IC Power Consumption Measurement

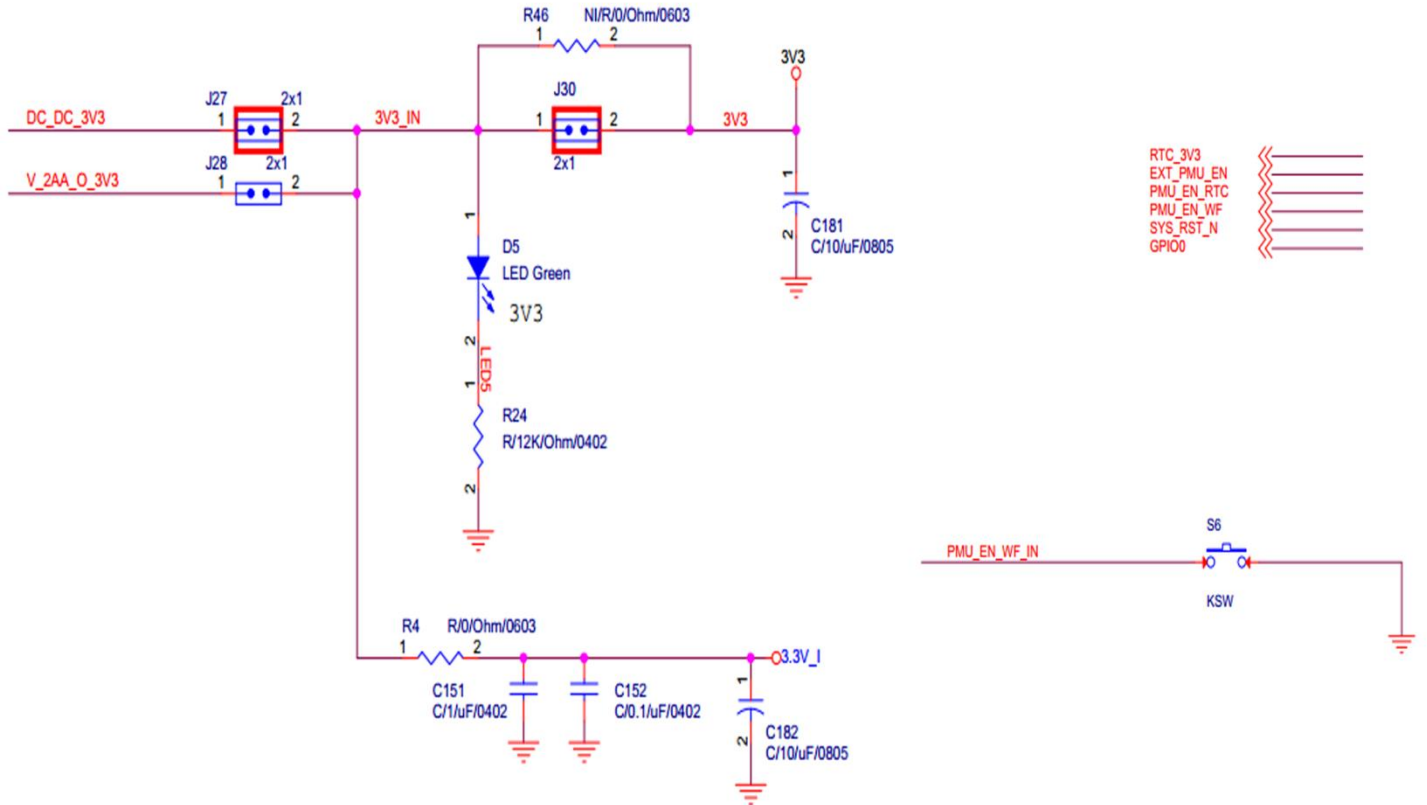

RTC Domain Power Measurement

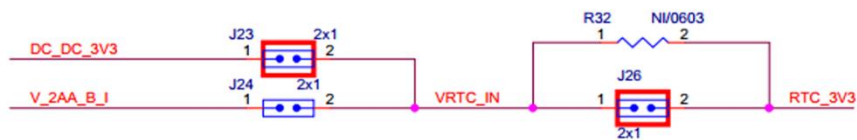

EINT (GPIO)

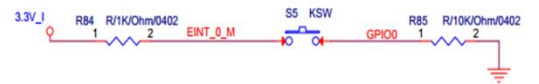

RTC INTERRUPT

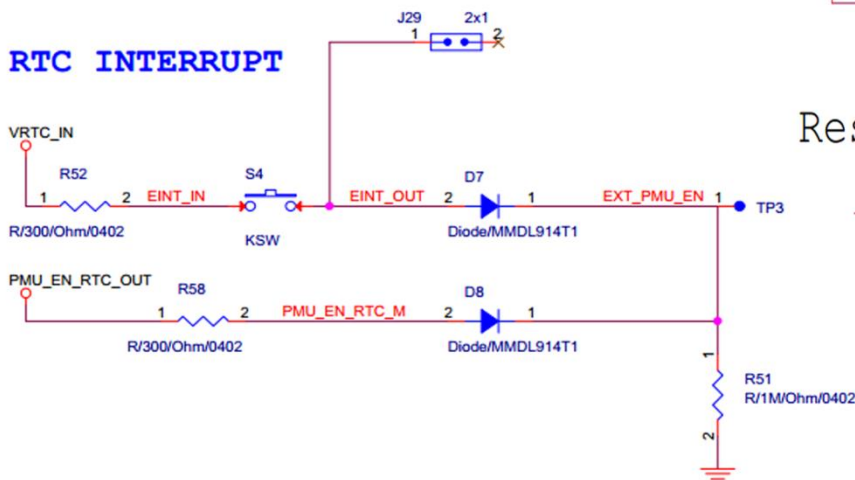

Reset Button

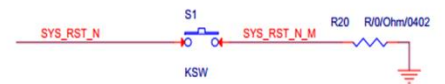

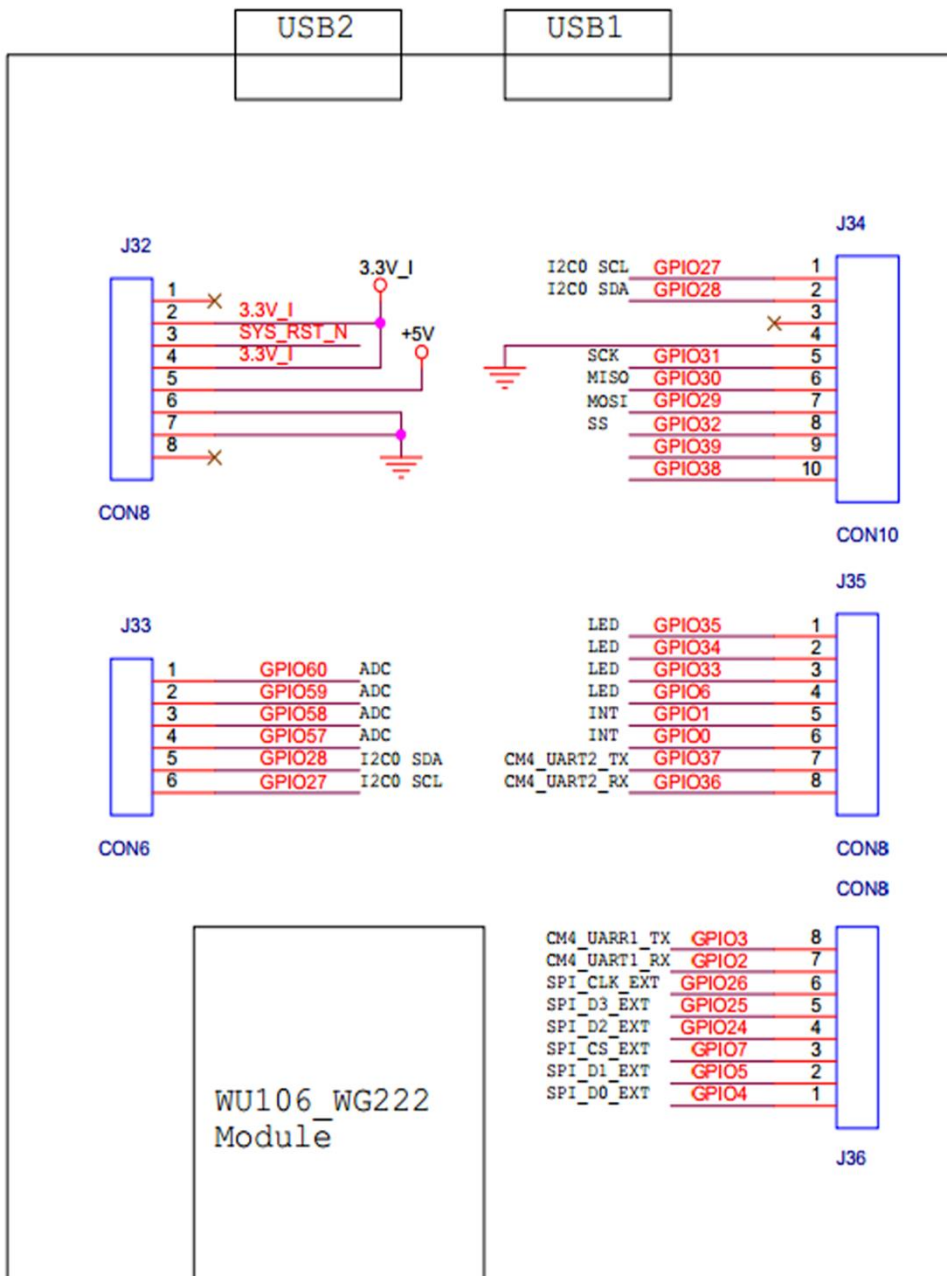
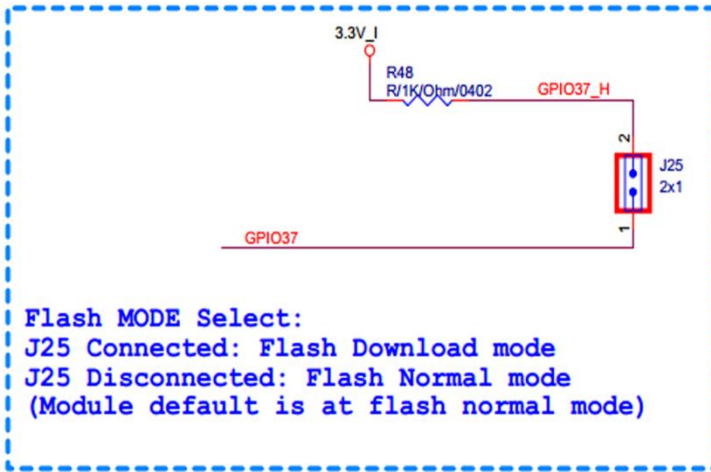

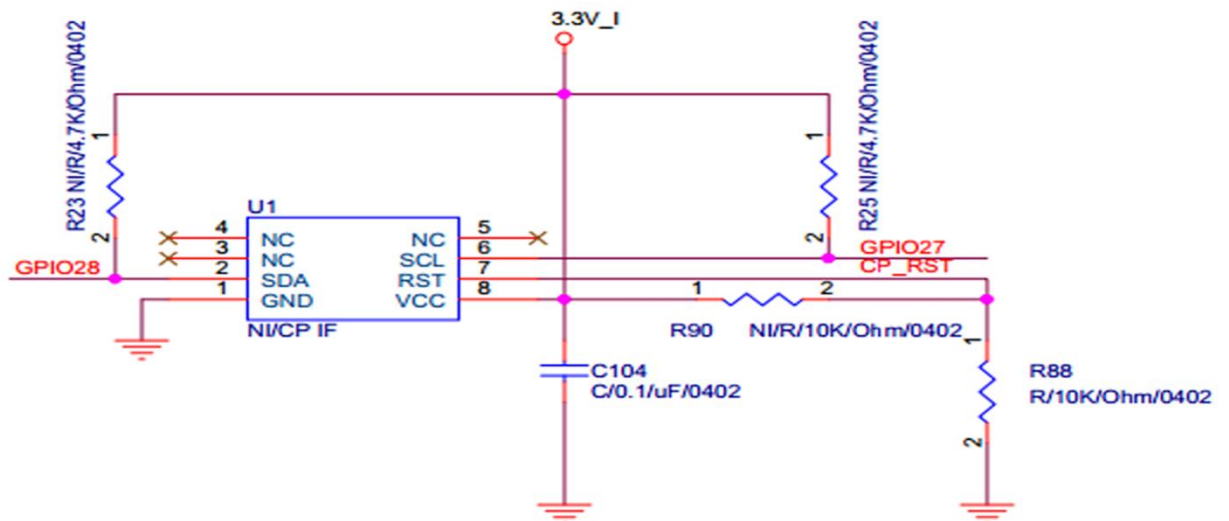
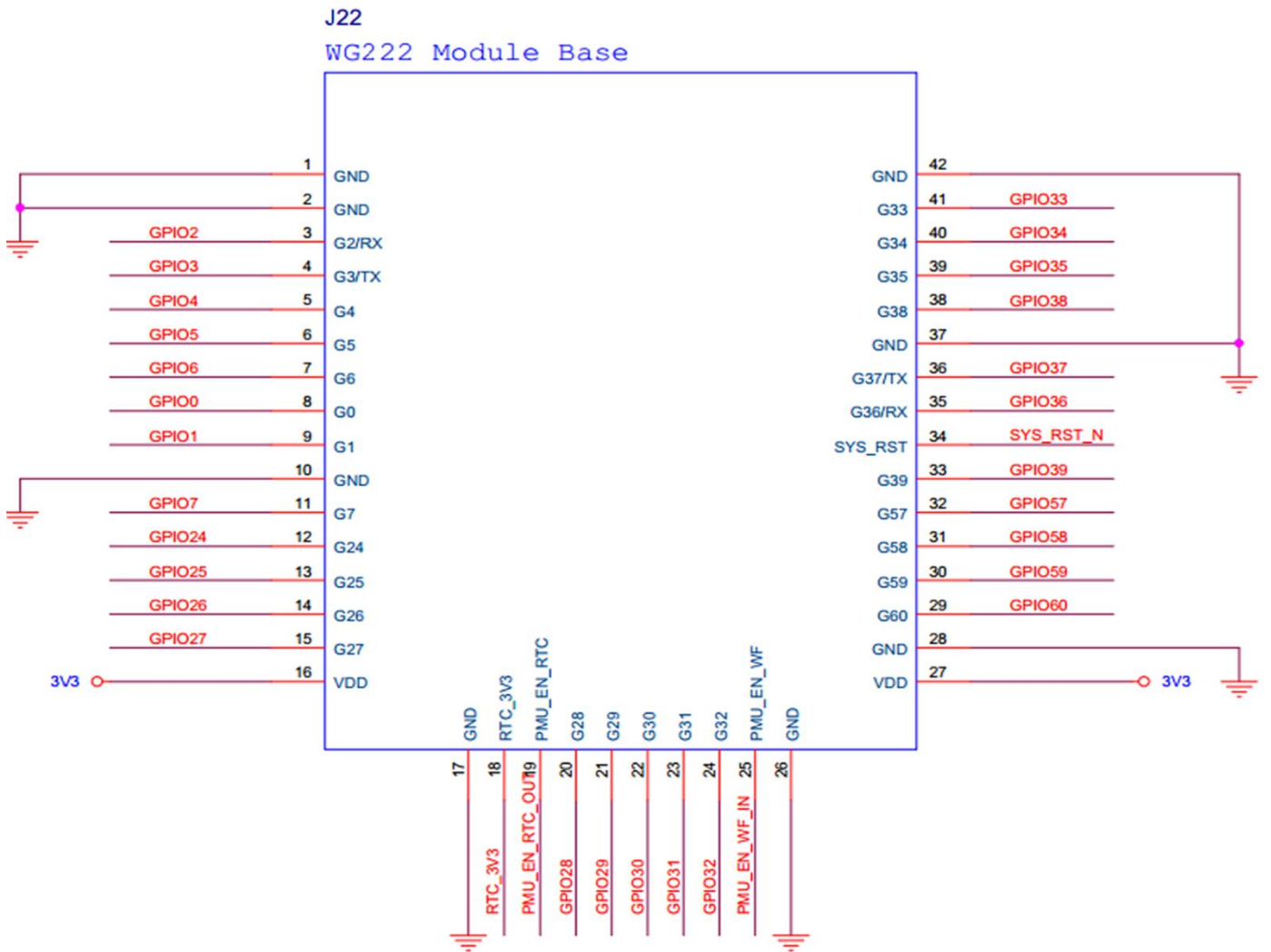

10 Manufacturing Process Recommendations

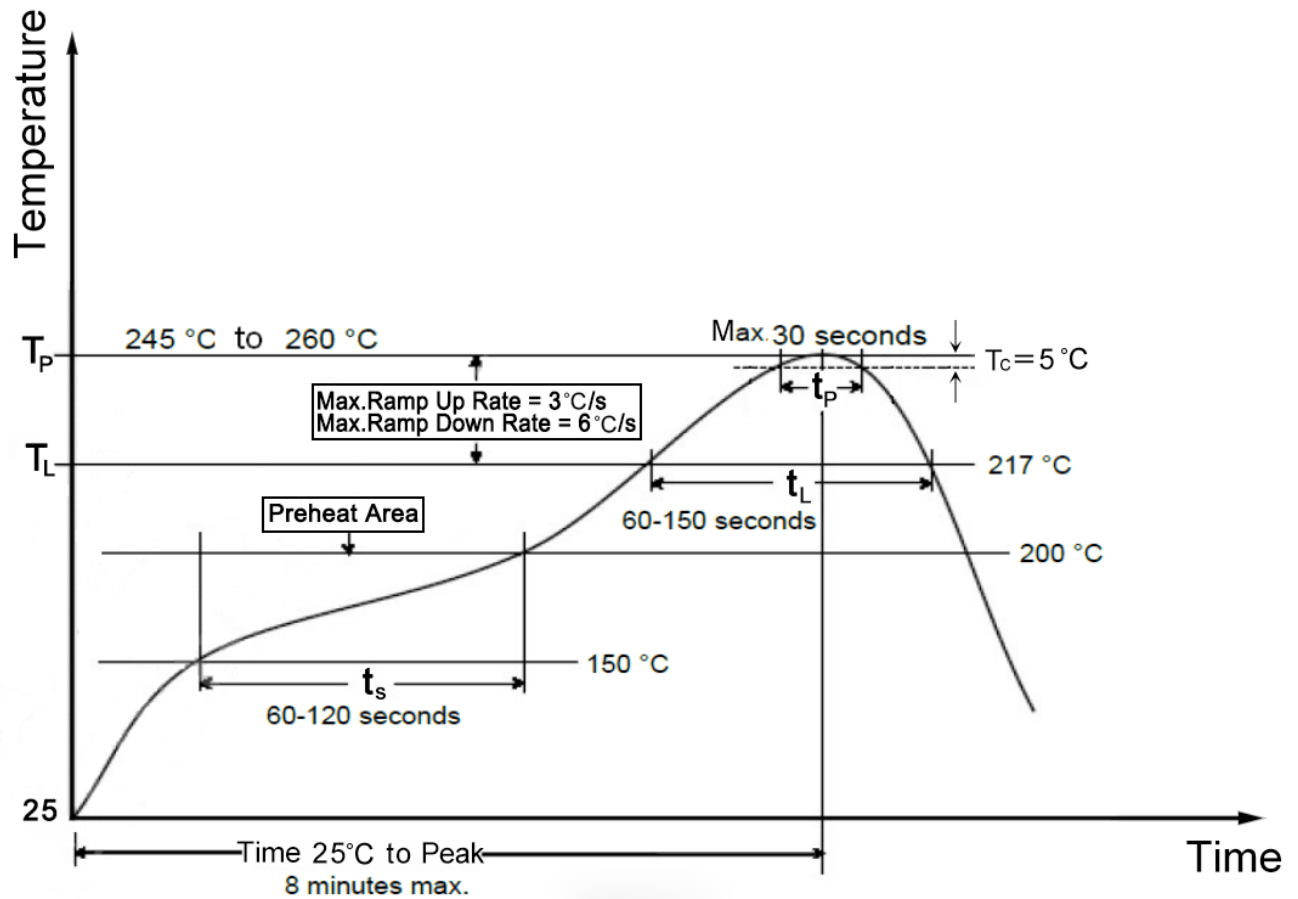
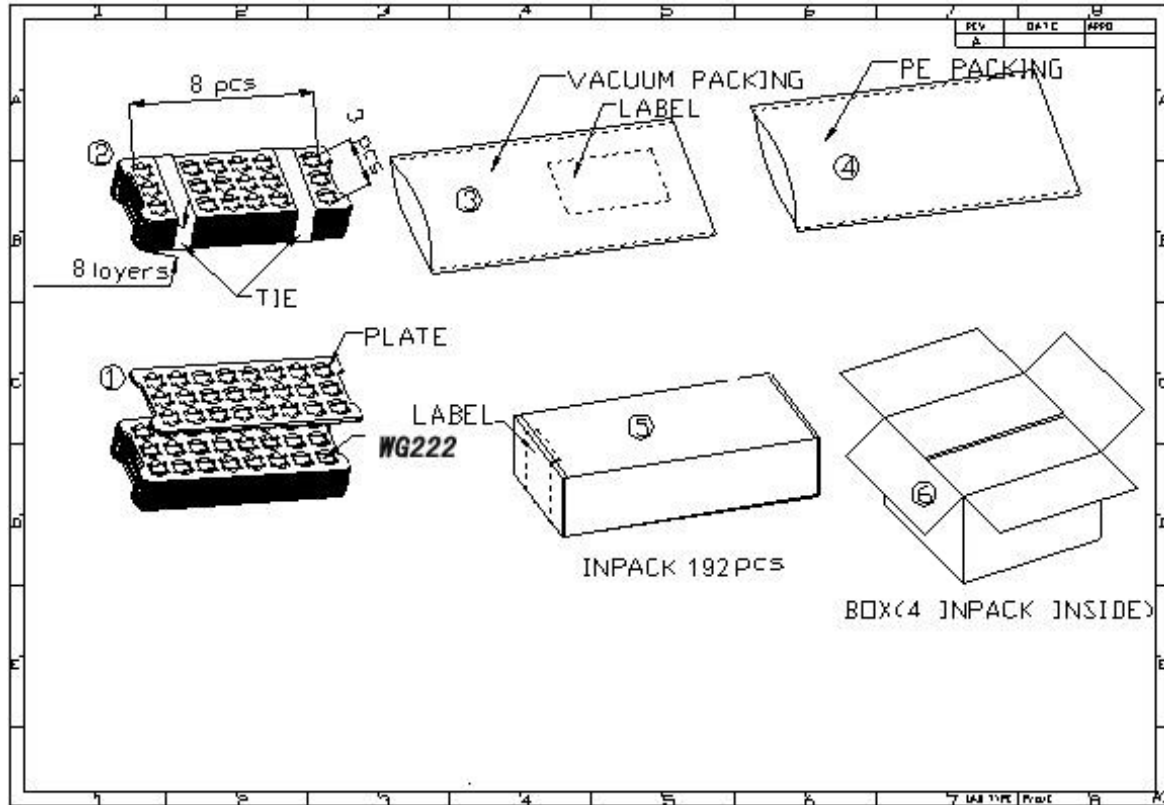

Figure 5: WG222 Typical Lead-free Soldering Profile

Note: The final soldering temperature chosen at the factory depends on additional external factors like choice of soldering paste, size, thickness and properties of the baseboard etc. Exceeding the maximum soldering temperature in the recommended soldering profile may permanently damage the module.

11 Packaging Specification



12 Ordering Information

Module No.	Antenna Connector Type
WG222P	PCB Antenna
WG222E	IPEX Connector

13 Revision history

Revision	Date	Name	Comments
V1.01	2018.02.11	George	Initial Release
V1.02	2018.03.03	George	Update Frequency Range
V1.03	2018.03.14	George	Update Performance Specification
V1.04	2018.04.17	George	update Packaging

V1.05	2018.05.03	George	update Module Pinout and Pin Description
V1.06	2018.05.23	George	update Dimensions Description
V1.07	2018.11.01	George	Add ADC Description
V1.08	2019.03.11	George	update Module Pin Description

14 Contact Information

Skylab M&C Technology Co., Ltd.

深圳市天工测控技术有限公司

Address: 6 Floor, No.9 Building, Lijincheng Scientific & Technical park, Gongye East Road,

Longhua District, Shenzhen, Guangdong, China

Phone: 86-755 8340 8210 (Sales Support)

Phone: 86-755 8340 8510 (Technical Support)

Fax: 86-755-8340 8560

E-Mail: technicalsupport@skylab.com.cn

Website: www.skylab.com.cn www.skylabmodule.com