

SKM81DC Datasheet

GLONASS/BD/GPS Module

Document information

Title	SKM81DC High-performance GLONASS/BD/GPS Solution Module Datasheet	
Document type	Datasheet	
Document number	SL-23040321	
Revision and date	V1.04	25-July-2023
Disclosure restriction	External Public	

Revision History:

Revision	Description	Approved	Date
V1.01	Initial Release to V1.01	Woody	20160225
V1.02	Update certification information	George	20170831
V1.03	Module size change from 18mm to 18.3mm	George	20190429
V1.04	Update product chart	Wendy	20230725

SKYLAB reserves all rights to this document and the information contained herein. Products, names, logos and designs described herein may in whole or in part be subject to intellectual property rights. Reproduction, use, modification or disclosure to third parties of this document or any part thereof without the express permission of SKYLAB is strictly prohibited.

The information contained herein is provided “as is” and SKYLAB assumes no liability for the use of the information. No warranty, either express or implied, is given, including but not limited, with respect to the accuracy, correctness, reliability and fitness for a particular purpose of the information. This document may be revised by SKYLAB at any time. For most recent documents, visit www.skylab.com.cn.

Copyright © 2016, Skylab M&C Technology Co., Ltd.

SKYLAB® is a registered trademark of Skylab M&C Technology Co., Ltd in China

目录

General Description 4

Applications 4

Features 5

Pin Assignmen5

Pin Description 5

Interfaces Configuration6

Advanced Software Features 6

Performance Specification 8

Electrical Characteristics9

 Absolute Maximum Rating9

 Operating Conditions 9

Mechanical Specification 10

Reference design schematic 11

Packaging Specification 11

Software Protocol 12

 NMEA 0183 Protocol 12

 GGA-Global Positioning System Fixed Data 12

 GLL-Geographic Position – Latitude/Longitude 14

 GSA-GNSS DOP and Active Satellites 14

 GSV-GNSS Satellites in View 15

 RMC-Recommended Minimum Specific GNSS Data 16

 VTG-Course Over Ground and Ground Speed 17

 ZDA-Date and Time 18

 CMD List 19

Contact Information 19

General Description

The SKM81DC is a complete GPS engine module that features super sensitivity, ultra low power and small form factor. The GPS signal is applied to the antenna input of module, and a complete serial data message with position, velocity and time information is presented at the serial interface with NMEA protocol or custom protocol.

It is based on the high performance features of the single-chip architecture, Its -165dBm tracking sensitivity extends positioning coverage into place like urban canyons and dense foliage environment where the GNSS was not possible before. The small form factor and low power consumption make the module easy to integrate into portable device like PNDs, mobile phones, cameras and vehicle navigation systems.

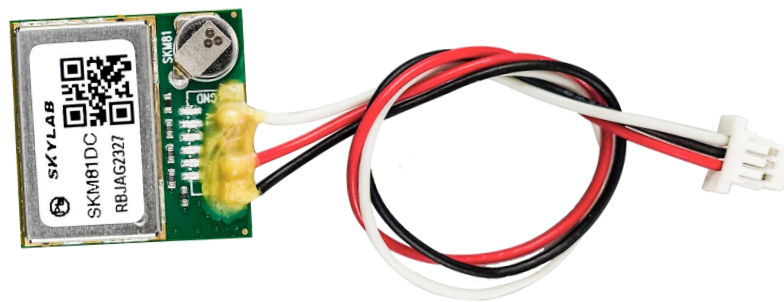

Figure 1: SKM81DC Top View

Applications

- LBS (Location Based Service)
- PND (Portable Navigation Device)
- Vehicle navigation system
- Mobile phone

Features

- GPS/GLONASS/BD/QZSS reseiver
- Ultra high sensitivity: -165dBm
- Extremely fast TTFF at low signal level
- Built-in 12 multi-tone active interference canceller
- Ultra low power consumption
- ±10ns high accuracy time pulse (1PPS)
- Advanced Features: AlwaysLocate; AIC; EPO;EASY
- SBAS (WAAS,EGNOS,MSAS,GAGAN)
- Small form factor: 18x18x6.3mm
- RoHS compliance (Lead-free)
- FCC,CE compliance

Pin Assignmen



Figure 2: SKM81DC Pin Assignment

Pin Description

Pin No.	Pin name	I/O	Description	Remark
1	VCC	P	Module Power Supply	Operating range: 3.3V to 5.5V
2	GND	G	Ground	
3	TX	O	UART Serial Data Output	Leave open if not used

Interfaces Configuration

Power Supply

Regulated power for the SKM81DC is required. The input voltage V_{cc} should be 3.3V to 5.5V range, current is no less than 100mA. Suitable decoupling must be provided by external decoupling circuitry (10uF and 1uF). It can reduce the Noise from power supply and increase power stability.

Main power supply V_{cc} current varies according to the processor load and satellite acquisition. Maximum V_{cc} peak current is about 40mA during acquisition.

UART Ports

The module supports one full duplex serial channels UART. The serial connections are at 2.85V LVTTTL logic levels, if need different voltage levels, use appropriate level shifters. the data format is however fixed: X, N, 8, 1, i.e. X baud rate, no parity, eight data bits and one stop bit, no other data formats are supported, LSB is sent first. The modules default baud rate is set up 9600bps.

Advanced Software Features

Standby Mode

User can issue software command to make GNSS module go into standby mode that consumes less than 200uA current. GNSS module will be awaked when receiving any byte. The following flow chart is an example to make GNSS module go into standby mode and then wake up.

Periodic Mode

When GNSS module is commanded to periodic mode, it will be in operation and standby periodically. Its status of power consumption is as below chart

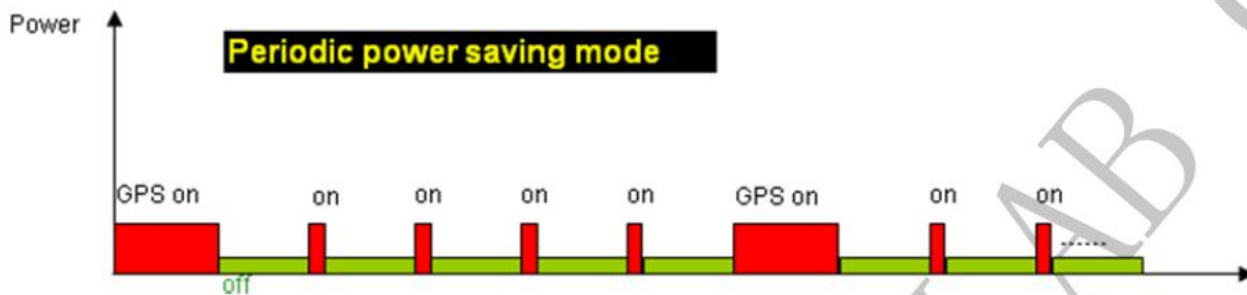

AlwaysLocate™

AlwaysLocate™ is an intelligent controller of periodic mode. Depending on the environment and motion conditions, GNSS module can adaptively adjust working/standby time to achieve balance of positioning accuracy and power consumption. In this mode, the host CPU does not need to control GNSS module until the host CPU needs the GPS position data. The following flow chart is an example to make GNSS module go into AlwaysLocate™ mode and then back to normal operation mode.

AGPS Support for Fast TTFF (EPO™)

The AGPS (EPO™) supply the predicated Extended Prediction Orbit data to speed TTFF ,users can download the EPO data to GPS engine from the FTP server by internet or wireless network ,the GPS engine will use the EPO data to assist position calculation when the navigation information of satellites are not enough or weak signal zone .

EASY™

The EASY™ is embedded assist system for quick positioning, the GPS engine will calculate and predict automatically the single emperies (Max. up to 3 days)when power on ,and save the predict information into the memory , GPS engine will use these information for positioning if no enough information from satellites , so the function will be helpful for positioning and TTFF improvement under indoor or urban condition ,the Backup power (VBACKUP) is necessary .

Embedded Logger function

The Embedded Logger function don't need host CPU (MCU) and external flash to handle the operation ,

GPS Engine will use internal flash (embedded in GPS chipset) to log the GPS data (Data format : UTC, Latitude , longitude, Valid ,Checksum), the max log days can up to 2 days under AlwaysLocate™ condition .

AIC_Multi-tone active interference canceller

Because different application (Wi-Fi , GSM/GPRS,3G/4G,Bluetooth)are integrated into navigation system , the harmonic of RF signal will influence the GPS reception , The multi- tone active-interference canceller can reject external RF interference which come from other active components on the main board , to improve the capacity of GPS reception without any needed HW change in the design .SKM81DC can cancel up to 12 independent channel interference continuous wave.

GNSS

The SKM81DC GNSS modules can receive and track multiple GNSS systems (e.g. GPS, GLONASS and BeiDou signals). The SKM81DC can be configure to start searching of which satellite system. By default the receivers are configured for concurrent GPS and GLONASS reception.

Performance Specification

Parameter	Specification	
Receiver Type	GPS, GLONASS, BD	
Sensitivity	Tracking	-165dBm Typical
	Acquisition	-148dBm Typical
Accuracy	Position	3.0m CEP50 without SA(Typical Open Sky)
	Velocity	0.1m/s without SA
	Timing (PPS)	10ns RMS
Acquisition Time	Cold Start	23s(Typical Open Sky)
	Warm Start	2-3s
	Hot Start	1s
	Re-Acquisition	<1s
Assisted GPS support	EPO	
Power Consumption	Tracking	25mA
	Acquisition	30mA

Navigation Data Update Rate	Max 10Hz	Default 1Hz
Operational Limits	Altitude	Max 18,000m
	Velocity	Max 515m/s
	Acceleration	Less than 4g

Electrical Characteristics

Absolute Maximum Rating

Parameter	Symbol	Min	Max	Units
Power Supply				
Power Supply Volt.	VCC	-0.3	6.5	V
Input Pins				
Input voltage on any input connection	VIO	-0.3	3.6	V
RF input power	RF_IN		-40	dBm
Human Body Model ESD capability	RF_IN		2000	V
Machine Model ESD capability	RF_IN		100	V
Environment				
Storage Temperature	Tstg	-40	125	°C
Humidity			95	%

Note: Absolute maximum ratings are stress ratings only, and functional operation at the maxims is not guaranteed. Stress beyond the limits specified in this table may affect device reliability or cause permanent damage to the device. For functional operating conditions, refer to the operating conditions tables as follow.

Operating Conditions

Parameter	Symbol	Condition	Min	Typ	Max	Units
Power supply voltage	Vcc		3.3	5	5.5	V
Power supply voltage ripple	Vcc_PP				30	mV
Supply current, Acquisition	Icc			30		mA

Supply current, Tracking	I _{CC}			25		mA
Input high voltage	V _{IH}		2		3.6	V
Input low voltage	V _{IL}		-0.3		0.8	V
Output high voltage	V _{OH}		2.4		3.1	V
Output low voltage	V _{OL}		-0.3		0.4	V
Operating temperature	T _{opr}		-40		85	°C

Mechanical Specification

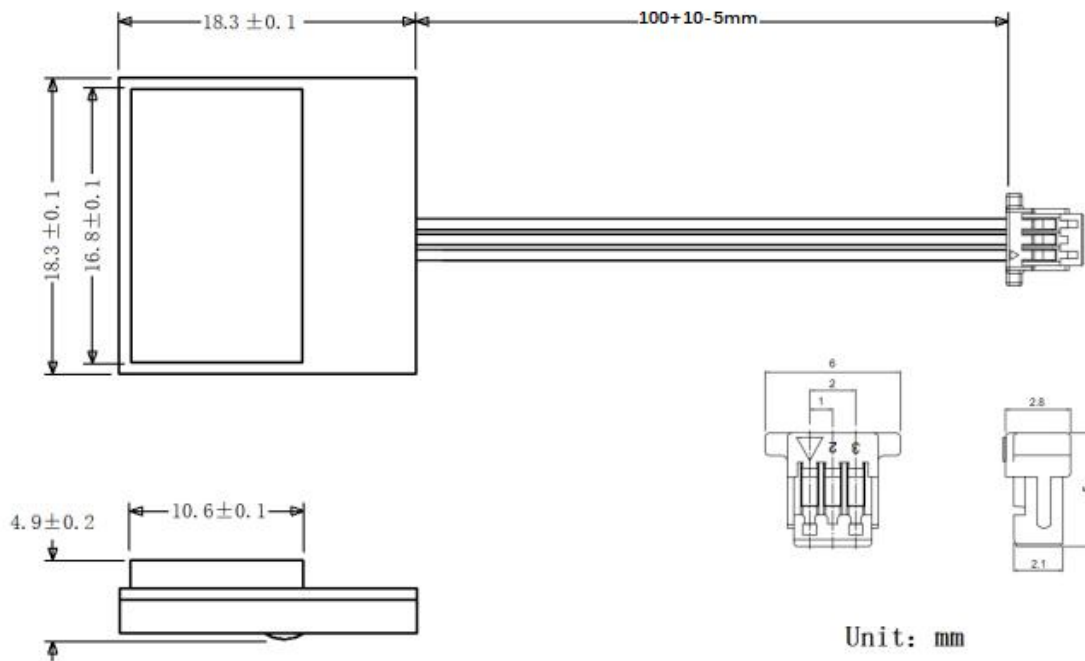

Figure 3: SKM81DC Dimensions

Reference design schematic

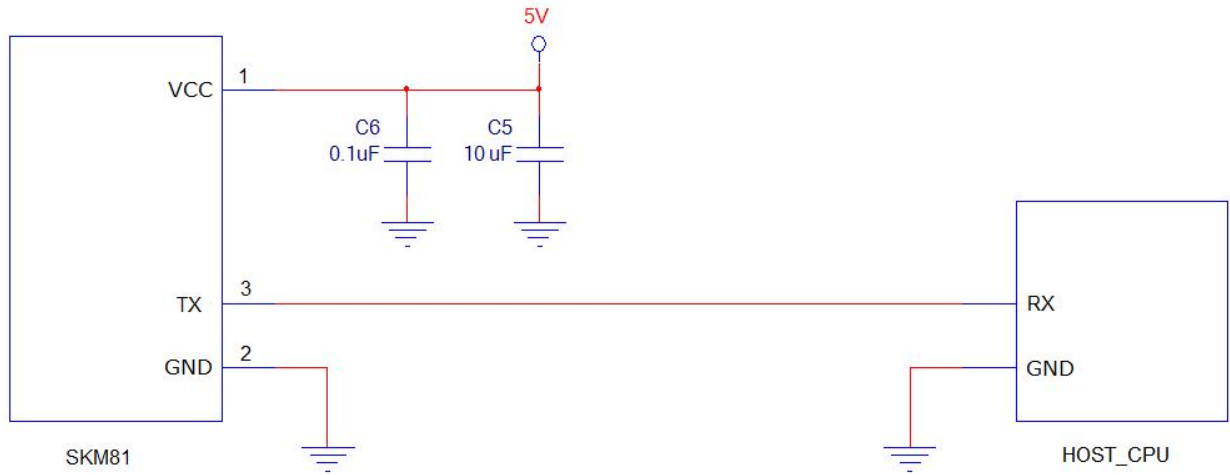

Figure 4: SKM81DC Typical Reference design schematic

Packaging Specification

modules are shipped in tray and with 48 units per tray. Each tray is 'dry' package.

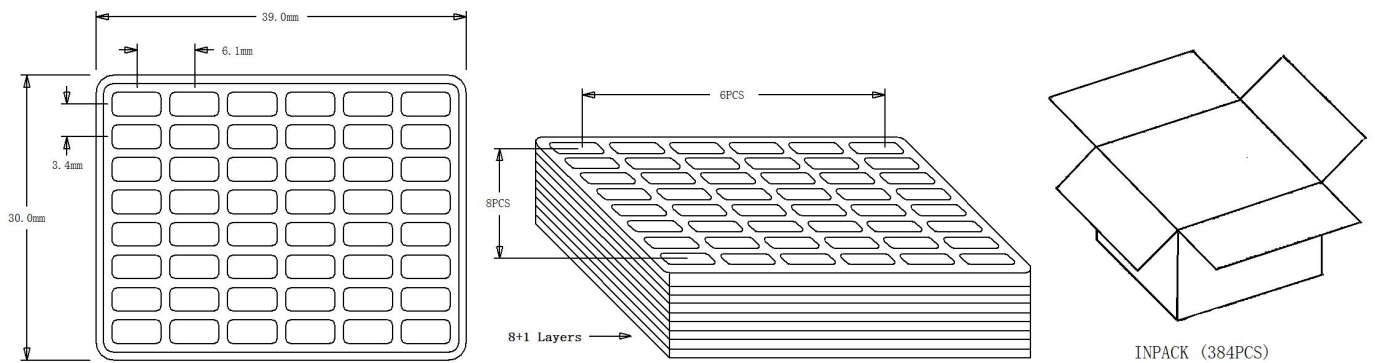

Figure 5: SKM81DC Packaging

Software Protocol

NMEA 0183 Protocol

The NMEA protocol is an ASCII-based protocol, Records start with a \$ and with carriage return/line feed. GPS specific messages all start with \$GNxxx where xxx is a three-letter identifier of the message data that follows. NMEA messages have a checksum, which allows detection of corrupted data transfers.

The Skylab SKM81DC supports the following NMEA-0183 messages: GGA, GLL, GSA, GSV, RMC VTG, ZDA. The module default NMEA-0183 output is set up GGA、GSA、RMC、GSV , and default baud rate is set up 9600bps.

Table 1: NMEA-0183 Output Messages

NMEA Record	Description	Default
GNGGA	Global positioning system fixed data	Y
GNGLL	Geographic position—latitude/longitude	N
GPGSA	GNSS DOP and active satellites for GPS	Y
GLGSA	GNSS DOP and active satellites for GLONASS	Y
BDGSA	Beidou DOP and active satellites for BD	N
GPGSV	GNSS satellites in view for GPS	Y
GLGSV	GNSS satellites in view for GLONASS	Y
BDGSV	Beidou satellites in view for BD	N
GNRMC	Recommended minimum specific GNSS data	Y
GNVTG	Course over ground and ground speed	N
GNZDA	Date and Time	N

GGA-Global Positioning System Fixed Data

This sentence contains the position, time and quality of the navigation fix.

See RMC for Fix Status, Fix Mode, Fix Date, Speed, and True Course.

See GSA for Fix Type, PDOP, and VDOP.

\$GNGGA,021514.000,2232.1799,N,11401.1823,E,1,6,1.25,84.0,M,-2.2,M,,*6A

Table 2: GGA Data Format

Name	Example	Units	Description
Message ID	\$GNGGA		GGA protocol header
UTC Position	021514.000		hhmmss.sss
Latitude	2232.1799		ddmm.mmmm
N/S indicator	N		N=north or S=south
Longitude	11401.1823		dddmm.mmmm
E/W Indicator	E		E=east or W=west
Position Fix Indicator	1		See Table 2-1
Satellites Used	6		Range 0 to 12
HDOP	1.25		Horizontal Dilution of Precision
MSL Altitude	84.0	meters	Altitude (referenced to the Ellipsoid)
AltUnit	M	meters	Altitude Unit
GeoSep	-2.2	meters	Geoidal Separation
GeoSepUnit	M	meters	Geoidal Separation Unit
Age of Diff.Corr.	<Null>	second	Null fields when it is not Used
Diff.Ref.Station ID	<Null>		Null fields when it is not Used
Checksum	*6A		
EOL	<CR> <LF>		End of message termination

Table 2-1: Position Fix Indicators

Value	Description
0	Fix not available or invalid
1	fix valid
2	Differential GPS, fix valid

GLL-Geographic Position – Latitude/Longitude

This sentence contains the fix latitude and longitude.

\$GNGLL,2232.1799,N,11401.1824,E,021513.000,A,A*4E

Table 3: GLL Data Format

Name	Example	Units	Description
Message ID	\$GNGLL		GLL protocol header
Latitude	2232.1799		ddmm.mmmm
N/S Indicator	N		N=north or S=south
Longitude	11401.1824		dddmm.mmmm
E/W Indicator	E		E=east or W=west
UTC Position	021513.000		hhmmss.sss
Fix Status	A		A=data valid or V=data not valid
Fix Mode	A		A=autonomous, N = No fix, D=DGPS, E=DR
Checksum	*4E		
EOL	<CR> <LF>		End of message termination

GSA-GNSS DOP and Active Satellites

This sentence contains the mode of operation, type of fix, PRNs of the satellites used in the solution as well as PDOP, HDOP and VDOP.

GPS GSA message: \$GPGSA,.....

\$GPGSA,A,3,28,20,04,17,10,193,08,,,,,1.14,0.75,0.85*31

GLONASS GSA message: \$GLGSA,.....

\$GLGSA,A,3,67,81,80,66,82,79,,,,,1.14,0.75,0.85*11

BD GSA message: \$BDGSA,.....

\$BDGSA,A,3,10,,,,,,,,,1.54,1.26,0.88*17

Table 4: GSA Data Format

Name	Example	Units	Description
Message	\$GPGSA		GSA protocol header
Mode 1	A		See Table 4-2
Mode 2	3		See Table 4-1
ID of satellite used	28		Sv on Channel 1
ID of satellite used	20		Sv on Channel 2
...
ID of satellite used	<Null>		Sv on Channel 12 (Null fields when it is not Used)
PDOP	1.14		Position Dilution of Precision
HDOP	0.75		Horizontal Dilution of Precision
VDOP	0.85		Vertical Dilution of Precision
Checksum	*31		
EOL	<CR> <LF>		End of message termination

Table 4-1: Mode 2

Value	Description
1	Fix not available
2	2D Fix
3	3D Fix

Table 4-2: Mode 1

Value	Description
M	Manual-forced to operate in 2D or 3D mode
A	Automatic-allowed to automatically switch 2D/3D

GSV-GNSS Satellites in View

This sentence contains the PRNs, azimuth, elevation, and signal strength of all satellites in view.

GPS GSV message: \$GPGSV,.....

\$GPGSV,4,1,14,28,86,009,35,193,70,056,38,04,44,258,29,17,44,338,44*48

GLONASS GSV message: \$GLGSV,.....

\$GLGSV,3,1,10,79,42,239,15,66,40,076,31,67,37,143,29,81,33,025,14*66

BD GSV message: \$BDGSV,.....

\$BDGSV,1,1,03,10,46,329,31,08,43,161,,09,40,217,*52

Table 5: GSV Data Format

Name	Example	Units	Description
Message ID	\$GPGSV		GSV protocol header
Number of Message	4		Total number of GSV sentences (Range 1 to 3)
Message Number	1		Sentence number of the total (Range 1 to 3)
Satellites in View	14		Number of satellites in view
Satellite ID	28		Channel 1
Elevation	86	degrees	Channel 1(Range 00 to 90)
Azinmuth	009	degrees	Channel 1(Range 000 to 359)
SNR(C/NO)	35	dB-Hz	Channel 1(Range 00 to 99, null when not tracking)
...			...
Satellite ID	17		Channel 4
Elevation	44	degrees	Channel 4(Range 00 to 90)
Azimuth	338	degrees	Channel 4(Range 000 to 359)
SNR(C/NO)	44	dB-Hz	Channel 4(Range 00 to 99, null when not tracking)
Checksum	*48		
EOL	<CR> <LF>		End of message termination

Depending on the number of satellites tracked multiple messages of GSV data may be required.

RMC-Recommended Minimum Specific GNSS Data

This sentence contains the recommended minimum fix information.

See GGA for Fix Quality, Sats Used, HDOP, Altitude, Geoidal Separation, and DGPS data.

See GSA for Fix Type, PDOP and VDOP.

\$GNRMC,023345.000,A,2232.1767,N,11401.1953,E,0.18,151.55,100410,,A*76

Table 6: RMC Data Format

Name	Example	Units	Description
Message ID	\$GNRMC		RMC protocol header
UTS Position	023345.000		hhmmss.sss
Status	A		A=data valid or V=data not valid
Latitude	2232.1767		ddmm.mmmm
N/S Indicator	N		N=north or S=south
Longitude	11401.1953		dddmm.mmmm
E/W Indicator	E		E=east or W=west
Speed Over Ground	0.18	Knots	
Course Over Ground	151.55	Degrees	True Course
Date(UTC)	100410		ddmmyy
Magnetic variation	<Null>	Degrees	Null fields when it is not Used
Magnetic Variation Direction	<Null>		E=east or W=west (Null fields when it is not Used)
Fix Mode	A		A=autonomous, N = No fix, D=DGPS, E=DR
Checksum	*76		
EOL	<CR> <LF>		End of message termination

VTG-Course Over Ground and Ground Speed

This sentence contains the course and speed of the navigation solution.

\$GNVTG,148.81,T,,M,0.13,N,0.24,K,A*23

Table 7: VTG Data Format

Name	Example	Units	Description
------	---------	-------	-------------

Message ID	\$GPVTG		VTG protocol header
Tcourse	148.81	Degrees	True Course
Reference	T		T = True
Mcourse	<Null>	Degrees	Magnetic Course (Null fields when it is not Used)
Reference	M		M = Magnetic (Null fields when it is not Used)
Speed over ground	0.13	Knots	Nautical Miles per Hour
Units	N		Knots
Speed over ground	0.24	Km/hr	in Kilometers per Hour
Units	K		Kilometer per hour
Mode	A		A=Autonomous, N=No fix, D=DGPS, E=DR
Checksum	*23		
EOL	<CR> <LF>		End of message termination

ZDA-Date and Time

This sentence contains UTC date & time, and local time zone offset information.

\$GNZDA,023345.000,10,04,2010,,*4D

Table 8: ZDA Data Format

Name	Example	Units	Description
Message ID	\$GPZDA		ZDA protocol header
UTC Time	023345.000		hhmmss.sss
Day	10		UTC time: day (01 ... 31) dd
Month	04		UTC time: month (01 ... 12) mm
Year	2010		UTC time: year (4 digit year) yyyy
local zone hours	<null>		Local Time Zone Offset Hours (Null fields when it is not Used)
local zone minutes	<null>		Local Time Zone Offset Minutes (Null fields when it is not Used)
Checksum	*4D		

EOL	<CR> <LF>	End of message termination
-----	-----------	----------------------------

CMD List

Table 9: CMD List

CMD TYPE	CMD Example:
Hot Restart	\$PMTK101*32<CR><LF>
Warm Restart	\$PMTK102*31<CR><LF>
Cold Restart	\$PMTK103*30<CR><LF>
Full Cold Restart	\$PMTK104*37<CR><LF>
Search GLONASS satellites only	\$PMTK353,0,1,0,0,0*2A<CR><LF>
Search GPS satellites only	\$PMTK353,1,0,0,0,0*2A<CR><LF>
Search GPS and GLONASS satellites	\$PMTK353,1,1,0,0,0*2B<CR><LF>
Search BEIDOU satellites only	\$PMTK353,0,0,0,0,1*2A<CR><LF>
Search GPS and BEIDOU satellites	\$PMTK353,1,0,0,0,1*2B<CR><LF>

Contact Information

Skylab M&C Technology Co., Ltd.

深圳市天工测控技术有限公司

Address: 6 Floor, No.9 Building, Lijincheng Scientific& Technicalpark, Gongye EastRoad,Longhua

District, Shenzhen, Guangdong, China

Phone: 86-755 8340 8210 (Sales Support)

Phone: 86-755 8340 8130 (Technical Support)

Fax: 86-755-8340 8560

E-Mail: sales1@skylab.com.cn

Website: www.skylab.com.cn www.skylabmodule.com.cn