

# GPS Module

# Datasheet

Name: Ultra High Sensitivity and Low Power GPS Receiver Module

Model No.: SKG17A

Revision: V4.04

## Revision History:

Revision	Description	Approved	Date
V1.01	Initial release	Neil	20080526
V2.01	GPS chip upgrade	Neil	20090406
V3.01	Increase active antenna supervisor	Neil	20111018
V4.01	Update chipset	George	20130708
V4.02	Update Firmware	Sunny	20140416
V4.03	Update Top View Photo	George	20170531
V4.04	Update certification information	George	20170831

## General Description

The SKG17A is a complete GPS engine module that features super sensitivity, ultra low power and small form factor. The GPS signal is applied to the antenna input of module, and a complete serial data message with position, velocity and time information is presented at the serial interface with NMEA protocol or custom protocol.

It is based on the high performance features of the MediaTek MT3339 single-chip architecture, Its  $-165\text{dBm}$  tracking sensitivity extends positioning coverage into place like urban canyons and dense foliage environment where the GPS was not possible before. The small form factor and low power consumption make the module easy to integrate into portable device like PNDs, mobile phones, cameras and vehicle navigation systems.

## Applications

- LBS (Location Based Service)
- PND (Portable Navigation Device)
- Vehicle navigation system
- Mobile phone



Figure 1: SKG17A Top View

## Features

- Ultra high sensitivity:  $-165\text{dBm}$
- Extremely fast TTFF at low signal level
- Built-in 12 multi-tone active interference canceller
- Ultra low power consumption
- $\pm 10\text{ns}$  high accuracy time pulse (1PPS)
- Advanced Features: AlwaysLocate; AIC; EPO;EASY,FLP
- QZSS, SBAS (WAAS,EGNOS,MSAS,GAGAN)
- Indoor and outdoor multi-path detection and compensation
- Small form factor:  $22.9 \times 17 \times 2.9\text{mm}$
- RoHS compliance (Lead-free)
- FCC,CE compliance

## Pin Assignment



Figure 2: SKG17A Pin Package

## Pin Description

Pin No.	Pin name	I/O	Description	Remark
1	NC		No Connection	
2	NC		No Connection	
3	TXD0	O	UART0 Serial Data Output	
4	RXD0	I	UART0 Serial Data Input	
5	NC		No Connection	
6	VCC	I	Module Power Supply	
7	GND	G	Ground	
8	NC		No Connection	
9	NC		No Connection	
10	RESET	I	Module Reset (Active Low)	Leave Open if not used
11	V_BCKP	P	RTC Battery Input	May be connect to Battery
12	NC		No Connection	
13	GND	G	Ground	
14	GND	G	Ground	
15	GND	G	Ground	
16	RF_IN	I	Antenna Input	50Ω
17	GND	G	Ground	
18	VCC_RF	O	Voltage Output for Active Antenna	If you use active antenna supervisor has to be use the VCC_RF supply power
19	V_ANT	I	Active Antenna External Voltage Supply	Leave Open if not used
20	AADET_N	I/O	Active Antenna Open-circuit detection	Leave Open if not used
21	NC		No Connection	
22	NC		No Connection	
23	NC		No Connection	
24	NC		No Connection	
25	NC		No Connection	
26	NC		No Connection	
27	EXTINT0	I	External Interrupt Pin(Default GPIO10)	Leave Open if not used
28	PPS	O	Time pulse Signal (Default 100ms)	Leave Open if not used

## Interfaces Configuration

### Power Supply

Regulated power for the SKG17A is required. The input voltage Vcc should be 3.0V to 4.2V range, current is no less

than 100mA. Suitable decoupling must be provided by external decoupling circuitry (10uF and 1uF). It can reduce the Noise from power supply and increase power stability.

Main power supply Vcc current varies according to the processor load and satellite acquisition. Maximum Vcc peak current is about 40 mA during acquisition.

### Backup Battery Power

In case of a power failure on pin Vcc, real-time clock and backup RAM are supplied through pin V\_BCKP. This enables the SKG17A GPS Receiver to recover from power failure with either a hot start or a warm start (depending on the duration of VCC outage). If no Backup Battery is connected, the receiver performs a cold start upon powered up.

Backup Battery Power V\_BCKP draws typically 15 uA current in backup state.

### Antenna

The SKG17A GPS receiver is designed for supporting the active antenna or passive antenna connected with pin RF\_IN. The gain of active antenna should be no more than 25dB (18~20dB Typical). The maximum noise figure should be no more than 1.5dB and output impedance is at 50 Ohm.

#### NOTE

**With passive antenna keep the cable loss at minimum(<1dB)**

### V\_ANT

Antenna power input pin. When user wants to use external active antenna. The pin supply power for active antenna.

### UART Ports

The module supports one full duplex serial channels UART. The serial connections are at 2.85V LVTTTL logic levels, if need different voltage levels, use appropriate level shifters. the data format is however fixed: X, N, 8, 1, i.e. X baud rate, no parity, eight data bits and one stop bit, no other data formats are supported, LSB is sent first. The modules default baud rate is set up 9600bps. The RXD0 & TXD0 recommended to pull up (10KΩ). It can increase the stability of serial data.

### EXTINT0

The default EXTINT1 function is Standby mode control but the function is not supported; leave signal floating (not connected).

### RF\_IN

The transmission line must to be control impedance from RF\_IN pin to the antenna or antenna connector of your choice. (Impedance 50Ω)

### VCC\_RF

The SKG17A Module supports the internal Antenna bias supply (VCC\_RF). You can connect VCC\_RF to V\_ANT, but it has some internal impedance that will cause a drop in supplied bias voltage, which depends on load current at external active antenna. Typical voltage drop from 3.3V is 0.3V at 18mA and 0.9V at 30mA active antenna current. If higher bias current is required, you can be provided by an external supply power connected to the V\_ANT.

#### NOTE

**If the customer needs to achieve antenna detection, the antenna must be connect VCC\_RF to V\_ANT. Active antenna current will be limited around 30mA ~40mA.**

### UART Ports

The module supports one full duplex serial channels UART. The serial connections are at 2.85V LVTTTL logic levels, if need different voltage levels, use appropriate level shifters. the data format is however fixed: X, N, 8, 1, i.e. X baud rate, no parity, eight data bits and one stop bit, no other data formats are supported, LSB is sent first. The modules default baud rate is set up 9600bps. The RXD0 & TXD0 recommended to pull up (10KΩ). It can increase the stability of serial data.

### Advanced Software Features

#### Standby Mode

User can issue software command to make GPS module go into standby mode that consumes less than 200uA current. GPS module will be awaked when receiving any byte. The following flow chart is an example to make GPS module go into standby mode and then wake up.

#### Periodic Mode

When GPS module is commanded to periodic mode, it will be in operation and standby periodically. Its status of power consumption is as below chart

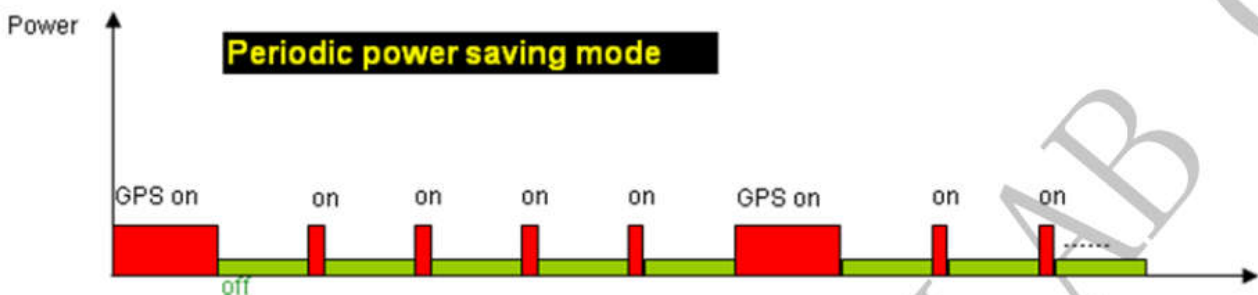

#### AlwaysLocate™

AlwaysLocate™ is an intelligent controller of periodic mode. Depending on the environment and motion conditions, GPS module can adaptively adjust working/standby time to achieve balance of positioning accuracy and power consumption. In this mode, the host CPU does not need to control GPS module until the host CPU needs the GPS position data. The following flow chart is an example to make GPS module go into AlwaysLocate™ mode and then back to normal operation mode.

#### AGPS Support for Fast TTFF (EPO™)

The AGPS (EPO™) supply the predicated Extended Prediction Orbit data to speed TTFF ,users can download the EPO data to GPS engine from the FTP server by internet or wireless network ,the GPS engine will use the EPO data to

assist position calculation when the navigation information of satellites are not enough or weak signal zone .

## EASY™

The EASY™ is embedded assist system for quick positioning, the GPS engine will calculate and predict automatically the single emperies ( Max. up to 3 days )when power on ,and save the predict information into the memory , GPS engine will use these information for positioning if no enough information from satellites , so the function will be helpful for positioning and TTFF improvement under indoor or urban condition ,the Backup power (VBACKUP) is necessary .

## Embedded Logger function

The Embedded Logger function don't need host CPU (MCU ) and external flash to handle the operation , GPS Engine will use internal flash (embedded in GPS chipset ) to log the GPS data (Data format : UTC, Latitude , longitude, Valid ,Checksum ), the max log days can up to 2 days under AlwaysLocate™ condition .

## AIC\_Multi-tone active interference canceller

Because different application (Wi-Fi , GSM/GPRS,3G/4G,Bluetooth )are integrated into navigation system , the harmonic of RF signal will influence the GPS reception , The multi- tone active-interference canceller can reject external RF interference which come from other active components on the main board , to improve the capacity of GPS reception without any needed HW change in the design .SKG17A can cancel up to 12 independent channel interference continuous wave.

## FLP Mode

With FLP mode,the power consumption can be reduced greatly, but positioning accuracy will be effected and need Special firmware to Support.

## Performance Specification

Parameter	Specification	
Receiver Type	L1 frequency band, C/A code, 22 Tracking / 66 Acquisition-Channel	
Sensitivity	Tracking	-165dBm Typical
	Acquisition	-148dBm Typical
Accuracy	Position	3.0m CEP50 without SA(Typical Open Sky)
	Velocity	0.1m/s without SA
	Timing (PPS)	10ns RMS
Acquisition Time	Cold Start	23s(Typical Open Sky)
	Warm Start	2-3s
	Hot Start	1s

	Re-Acquisition	<1s
Assisted GPS support	EPO	
Power Consumption	Tracking Acquisition	22mA @3.3V Typical    14 mA@ FLP mode 25mA @3.3V                25mA@ FLP mode
Navigation Data Update Rate	Max 10Hz	Default 1Hz
Operational Limits	Altitude Velocity Acceleration	Max 18,000m Max 515m/s Less than 4g

## Electrical Characteristics

### Absolute Maximum Rating

Parameter	Symbol	Min	Max	Units
<b>Power Supply</b>				
Power Supply Volt.	VCC	-0.3	4.3	V
<b>Input Pins</b>				
Input voltage on any input connection	VIO	-0.3	3.6	V
Backup Battery	V_BCKP	-0.3	4.3	V
RF input power	RF_IN		10	dBm
Human Body Model ESD capability	RF_IN		2000	V
Machine Model ESD capability	RF_IN		100	V
<b>Environment</b>				
Storage Temperature	Tstg	-40	125	°C
Peak Reflow Soldering Temperature <10s	Tpeak		260	°C
Humidity			95	%

Note: Absolute maximum ratings are stress ratings only, and functional operation at the maxims is not guaranteed. Stress beyond the limits specified in this table may affect device reliability or cause permanent damage to the device. For functional operating conditions, refer to the operating conditions tables as follow.

The SKG17A module is Electrostatic Sensitive Device (ESD) and may be damaged with ESD or spike voltage. Although it has built-in ESD protection circuitry at digital I/O, please handle with care to avoid permanent malfunction or performance degradation. Note that RFIN has no ESD protection circuits.

### Operating Conditions

Parameter	Symbol	Condition	Min	Typ	Max	Units
-----------	--------	-----------	-----	-----	-----	-------

Power supply voltage	V <sub>cc</sub>		3	3.3	4.2	V
Backup Battery	V <sub>BCKP</sub>		2	3.3	4.2	V
Power supply voltage ripple	V <sub>cc_PP</sub>	V <sub>cc</sub> =3.3V			30	mV
Supply current, navigation	I <sub>cc</sub>	V <sub>cc</sub> =3.3V		22	28	mA
Supply current, backup state	I <sub>bckp</sub>	V <sub>cc</sub> =3.3V		7		uA
VCC_RF Antenna bias supply	VCC_OUT	I <sub>ANT</sub> = 18 mA		3		V
Input high voltage	V <sub>IH</sub>		2		3.6	V
Input low voltage	V <sub>IL</sub>		-0.3		0.8	V
Output high voltage	V <sub>OH</sub>		2.4		3.1	V
Output low voltage	V <sub>OL</sub>		-0.3		0.4	V
Operating temperature	T <sub>opr</sub>		-40		85	°C

### Mechanical Specification

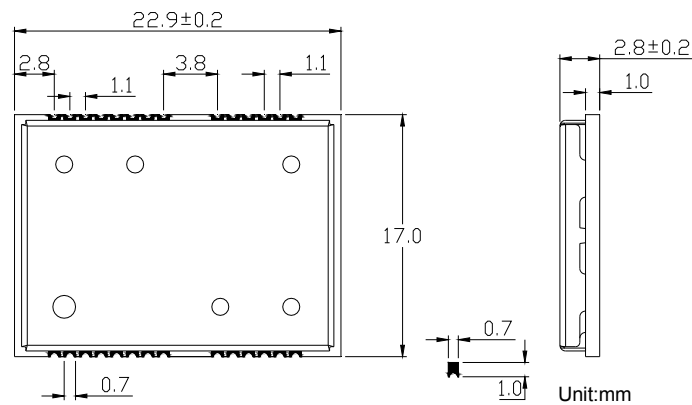

Figure 3: SKG17A Dimensions

### Recommend Layout



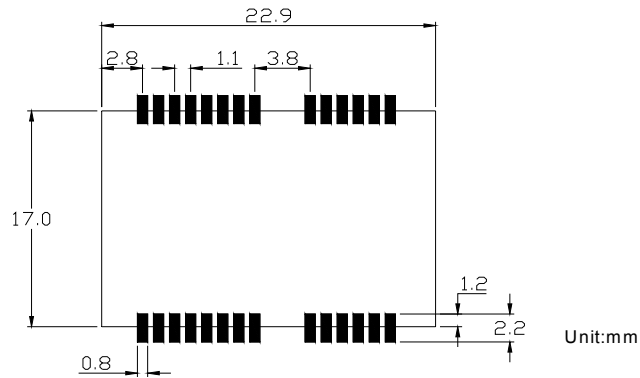

Figure 4: SKG17A Footprint

**Reference design schematic**

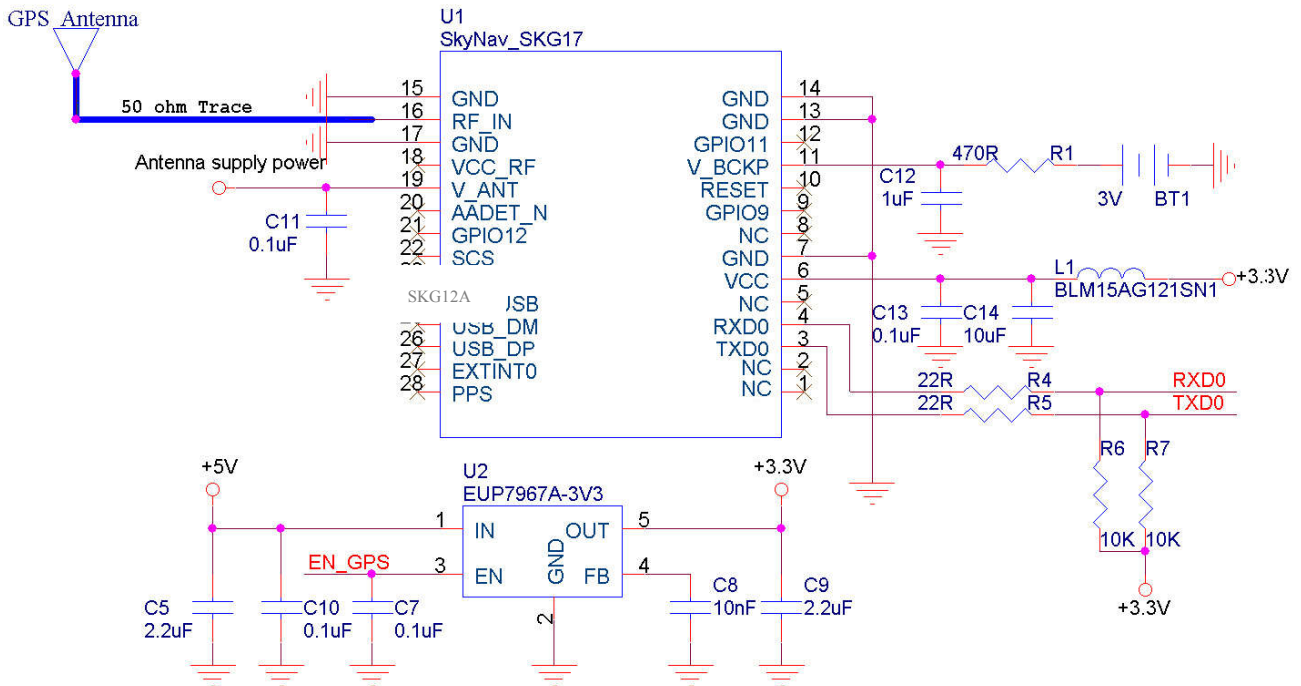

Figure 5: SKG17A Typical Reference design schematic

**Packaging Specification**

SKG17A modules are shipped in tray and with 24 units per tray. Each tray is 'dry' package.

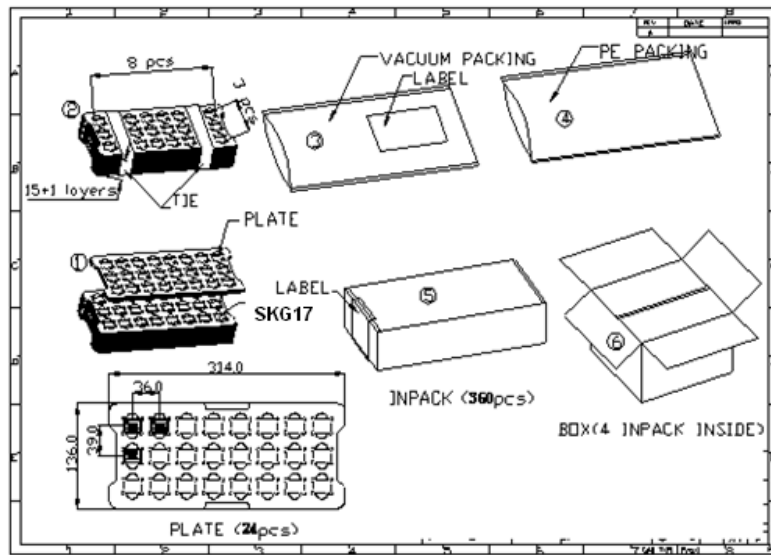

Figure 6: SKG17A Packaging

**Manufacturing Process Recommendations**

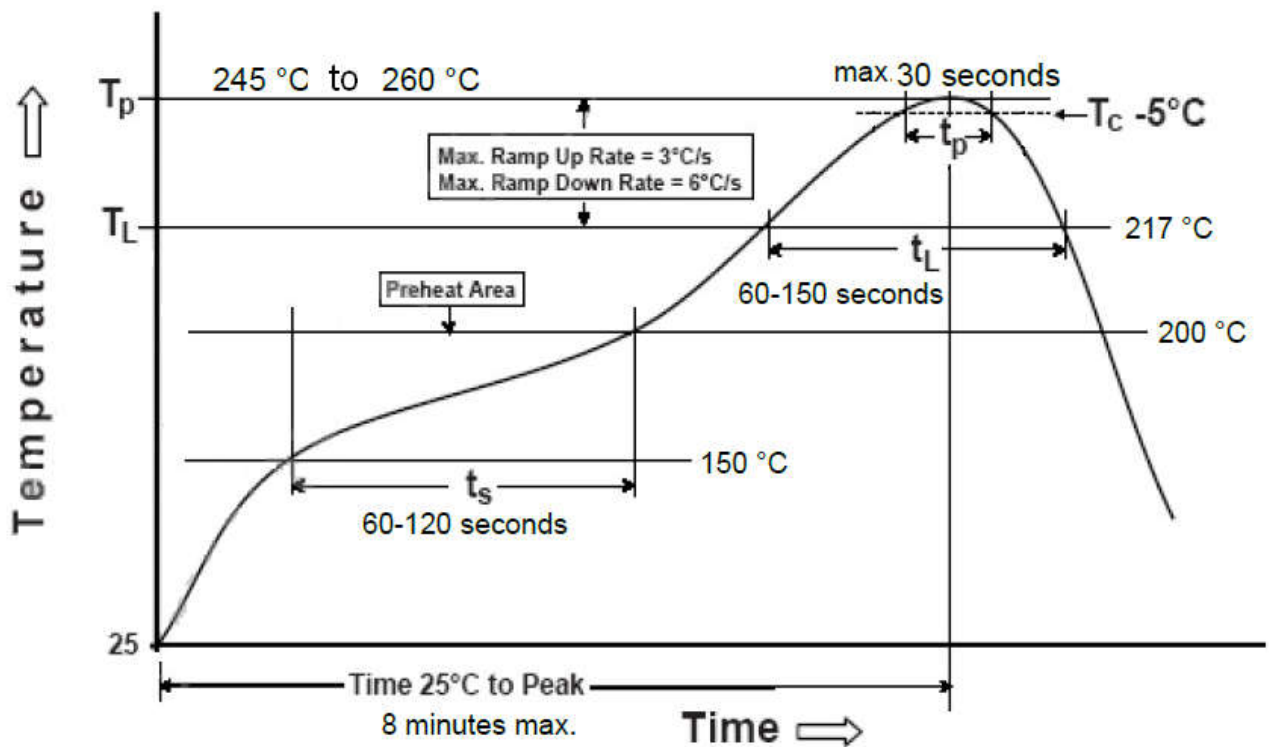

Figure 7: SKG17A Typical Leadfree Soldering Profile

**Note:** The final soldering temperature chosen at the factory depends on additional external factors like choice of soldering paste, size, thickness and properties of the baseboard, etc. Exceeding the maximum soldering temperature in the recommended soldering profile may permanently damage the module.

## Software Protocol

### NMEA 0183 Protocol

The NMEA protocol is an ASCII-based protocol, Records start with a \$ and with carriage return/line feed. GPS specific messages all start with \$GPxxx where xxx is a three-letter identifier of the message data that follows. NMEA messages have a checksum, which allows detection of corrupted data transfers.

The Skylab SKG17A supports the following NMEA-0183 messages: GGA, GLL, GSA, GSV, RMC, VTG, ZDA. The module default NMEA-0183 output is set up GGA, GSA, RMC, GSV, and default baud rate is set up 9600bps.

Table 1: NMEA-0183 Output Messages

NMEA Record	Description	Default
GGA	Global positioning system fixed data	Y
GLL	Geographic position—latitude/longitude	N
GSA	GNSS DOP and active satellites	Y
GSV	GNSS satellites in view	Y
RMC	Recommended minimum specific GNSS data	Y
VTG	Course over ground and ground speed	N
ZDA	Date and Time	N

### GGA-Global Positioning System Fixed Data

This sentence contains the position, time and quality of the navigation fix.

See RMC for Fix Status, Fix Mode, Fix Date, Speed, and True Course.

See GSA for Fix Type, PDOP, and VDOP.

\$GPGGA,021514.000,2232.1799,N,11401.1823,E,1,6,1.25,84.0,M,-2.2,M,,\*74

Table 2: GGA Data Format

Name	Example	Units	Description
Message ID	\$GPGGA		GGA protocol header
UTC Position	021514.000		hhmmss.sss
Latitude	2232.1799		ddmm.mmmm
N/S indicator	N		N=north or S=south

Longitude	11401.1823		dddmm.mmmm
E/W Indicator	E		E=east or W=west
Position Fix Indicator	1		See Table 2-1
Satellites Used	6		Range 0 to 12
HDOP	1.25		Horizontal Dilution of Precision
MSL Altitude	84.0	meters	Altitude (referenced to the Ellipsoid)
AltUnit	M	meters	Altitude Unit
GeoSep	-2.2	meters	Geoidal Separation
GeoSepUnit	M	meters	Geoidal Separation Unit
Age of Diff.Corr.	<Null>	second	Null fields when it is not Used
Diff.Ref.Station ID	<Null>		Null fields when it is not Used
Checksum	*74		
EOL	<CR> <LF>		End of message termination

Table 2-1: Position Fix Indicators

Value	Description
0	Fix not available or invalid
1	GPS SPS Mode, fix valid
2	Differential GPS, SPS Mode, fix valid
3	GPS PPS Mode, fix valid

### GLL-Geographic Position – Latitude/Longitude

This sentence contains the fix latitude and longitude.

\$GPGLL,2232.1799,N,11401.1824,E,021513.000,A,A\*50

Table 3: GLL Data Format

Name	Example	Units	Description
Message ID	\$GPGLL		GLL protocol header
Latitude	2232.1799		ddmm.mmmm
N/S Indicator	N		N=north or S=south
Longitude	11401.1824		dddmm.mmmm
E/W Indicator	E		E=east or W=west
UTC Position	021513.000		hhmmss.sss
Fix Status	A		A=data valid or V=data not valid
Fix Mode	A		A=autonomous, N = No fix, D=DGPS, E=DR
Checksum	*50		
EOL	<CR> <LF>		End of message termination

### GSA-GNSS DOP and Active Satellites

This sentence contains the mode of operation, type of fix, PRNs of the satellites used in the solution as well as PDOP, HDOP and VDOP.

\$GPGSA,A,3,26,05,18,15,27,29,,,,,,,,,1.52,1.25,0.87\*0F

Table 4: GSA Data Format

Name	Example	Units	Description
Message	\$GPGSA		GSA protocol header
Mode 1	A		See Table 4-2
Mode 2	3		See Table 4-1
ID of satellite used	26		Sv on Channel 1
ID of satellite used	05		Sv on Channel 2
...	...		...
ID of satellite used	<Null>		Sv on Channel 12 (Null fields when it is not Used)
PDOP	1.52		Position Dilution of Precision
HDOP	1.25		Horizontal Dilution of Precision
VDOP	0.87		Vertical Dilution of Precision
Checksum	*0F		
EOL	<CR> <LF>		End of message termination

Table 4-1: Mode 1

Value	Description
1	Fix not available
2	2D Fix
3	3D Fix

Table 4-2: Mode 2

Value	Description
M	Manual-forced to operate in 2D or 3D mode
A	Automatic-allowed to automatically switch 2D/3D

### GSV-GNSS Satellites in View

This sentence contains the PRNs, azimuth, elevation, and signal strength of all satellites in view.

\$GPGSV,3,1,12,15,79,333,42,42,50,127,,29,45,263,44,02,36,124,30\*7E

\$GPGSV,3,2,12,26,36,226,34,05,35,046,22,27,33,161,29,21,16,319,\*7D

\$GPGSV,3,3,12,10,15,066,31,18,14,285,45,24,12,319,15,08,09,047,18\*7E

Table 5: GSV Data Format

Name	Example	Units	Description
Message ID	\$GPGSV		GSV protocol header
Number of Message	3		Total number of GSV sentences (Range 1 to 3)
Message Number	1		Sentence number of the total (Range 1 to 3)
Satellites in View	12		Number of satellites in view
Satellite ID	15		Channel 1(Range 01 to 32)
Elevation	79	degrees	Channel 1(Range 00 to 90)
Azimuth	333	degrees	Channel 1(Range 000 to 359)

SNR(C/NO)	42	dB-Hz	Channel 1(Range 00 to 99, null when not tracking)
...			...
Satellite ID	02		Channel 4(Range 01 to 32)
Elevation	36	degrees	Channel 4(Range 00 to 90)
Azimuth	124	degrees	Channel 4(Range 000 to 359)
SNR(C/NO)	30	dB-Hz	Channel 4(Range 00 to 99, null when not tracking)
Checksum	*7E		
EOL	<CR> <LF>		End of message termination

Depending on the number of satellites tracked multiple messages of GSV data may be required.

### RMC-Recommended Minimum Specific GNSS Data

This sentence contains the recommended minimum fix information.

See GGA for Fix Quality, Sats Used, HDOP, Altitude, Geoidal Separation, and DGPS data.

See GSA for Fix Type, PDOP and VDOP.

\$GPRMC,023345.000,A,2232.1767,N,11401.1953,E,0.18,151.55,100410,,A\*6B

Table 6: RMC Data Format

Name	Example	Units	Description
Message ID	\$GPRMC		RMC protocol header
UTS Position	023345.000		hhmmss.sss
Status	A		A=data valid or V=data not valid
Latitude	2232.1767		ddmm.mmmm
N/S Indicator	N		N=north or S=south
Longitude	11401.1953		dddmm.mmmm
E/W Indicator	E		E=east or W=west
Speed Over Ground	0.18	Knots	
Course Over Ground	151.55	Degrees	True Course
Date(UTC)	100410		ddmmyy
Magnetic variation	<Null>	Degrees	Null fields when it is not Used
Magnetic Variation Direction	<Null>		E=east or W=west (Null fields when it is not Used)
Fix Mode	A		A=autonomous, N = No fix, D=DGPS, E=DR
Checksum	*6B		
EOL	<CR> <LF>		End of message termination

### VTG-Course Over Ground and Ground Speed

This sentence contains the course and speed of the navigation solution.

\$GPVTG,148.81,T,,M,0.13,N,0.24,K,A\*3D

Table 7: VTG Data Format

Name	Example	Units	Description
Message ID	\$GPVTG		VTG protocol header

Tcourse	148.81	Degrees	True Course
Reference	T		T = True
Mcourse	<Null>	Degrees	Magnetic Course (Null fields when it is not Used)
Reference	M		M = Magnetic (Null fields when it is not Used)
Speed over ground	0.13	Knots	Nautical Miles per Hour
Units	N		Knots
Speed over ground	0.24	Km/hr	in Kilometers per Hour
Units	K		Kilometer per hour
Mode	A		A=Autonomous, N=No fix, D=DGPS, E=DR
Checksum	*3D		
EOL	<CR> <LF>		End of message termination

**ZDA-Date and Time**

This sentence contains UTC date & time, and local time zone offset information.

\$GPZDA,023345.000,10,04,2010,,\*50

Table 8: ZDA Data Format

Name	Example	Units	Description
Message ID	\$GPZDA		ZDA protocol header
UTC Time	023345.000		hhmmss.sss
Day	10		UTC time: day (01 ... 31) dd
Month	04		UTC time: month (01 ... 12) mm
Year	2010		UTC time: year (4 digit year) yyyy
local zone hours	<null>		Local Time Zone Offset Hours (Null fields when it is not Used)
local zone minutes	<null>		Local Time Zone Offset Minutes (Null fields when it is not Used)
Checksum	*50		
EOL	<CR> <LF>		End of message termination

**NMEA CMD List**

NMEA CMD TYPE	NMEA CMD Example:
Hot Restart	\$PMTK101*32<CR><LF>
Warm Restart	\$PMTK102*31<CR><LF>
Cold Restart	\$PMTK103*30<CR><LF>
Full Cold Restart	\$PMTK104*37<CR><LF>
port baudrate	\$PMTK251,38400*27<CR><LF>

## Skylab M&C Technology Co., Ltd.

深圳市天工测控技术有限公司

**Address:** 6 Floor, No.9 Building, Lijincheng Scientific&Technical park, Gongye East Road, Longhua District, Shenzhen, Guangdong, China

**Phone:** 86-755 8340 8210 (Sales Support)

**Phone:** 86-755 8340 8130 (Technical Support)

**Fax:** 86-755-8340 8560

**E-Mail:** [technicalsupport@skylab.com.cn](mailto:technicalsupport@skylab.com.cn)

**Website:** [www.skylab.com.cn](http://www.skylab.com.cn)    [www.skylabmodule.com.cn](http://www.skylabmodule.com.cn)