



GPS Module DataSheet

Name: Ultra High Sensitivity and Low Power GPS Receiver Module

Model NO.: SKM55

Revision: 001

Revision History:

Revision	Description	Approved	Date
001	Initial Release to 001	Neil	20100601

Skylab M&C Technology Co., Ltd.

Address: Room.801, Bldg.211, Terra Industrial Park, Futian District, Shenzhen

Phone: 86-755 8340 8210 (Sales Support)

Phone: 86-755 8340 8130 (Technical Support)

Fax: 86-755-8340 8560

E-Mail: sales@skylab.com.cn

©Copyright 2010 Skylab M&C Co., Ltd, All Right Reserved

The information contained herein is subject to change without notice.

General Description

The SkyNav SKM55 Series with embedded GPS antenna enables high performance navigation in the most stringent applications and solid fix even in harsh GPS visibility environments.

It is based on the high performance features of the MediaTek 3329 single-chip architecture, Its -165dBm tracking sensitivity extends positioning coverage into place like urban canyons and dense foliage environment where the GPS was not possible before. The UART and USB connector design is the easiest and convenient solution to communication with other electronic equipment.



Figure 1: SKM55 Top View

Applications

- LBS (Location Based Service)
- PND (Portable Navigation Device)
- Vehicle navigation system
- Mobile phone

Features

- Ultra high sensitivity: -165dBm
- 22 tracking/66 acquisition-channel receiver
- WAAS/EGNOS/MSAS/GAGAN support
- NMEA protocols (default speed: 9600bps)
- Internal back-up battery
- One serial port
- Embedded patch antenna 25 x 25 x 4.0 mm
- Operating temperature range: -40 to 85°C
- RoHS compliant (Lead-free)
- Tiny form factor : 46 * 45 * 15mm

Pin Assignment

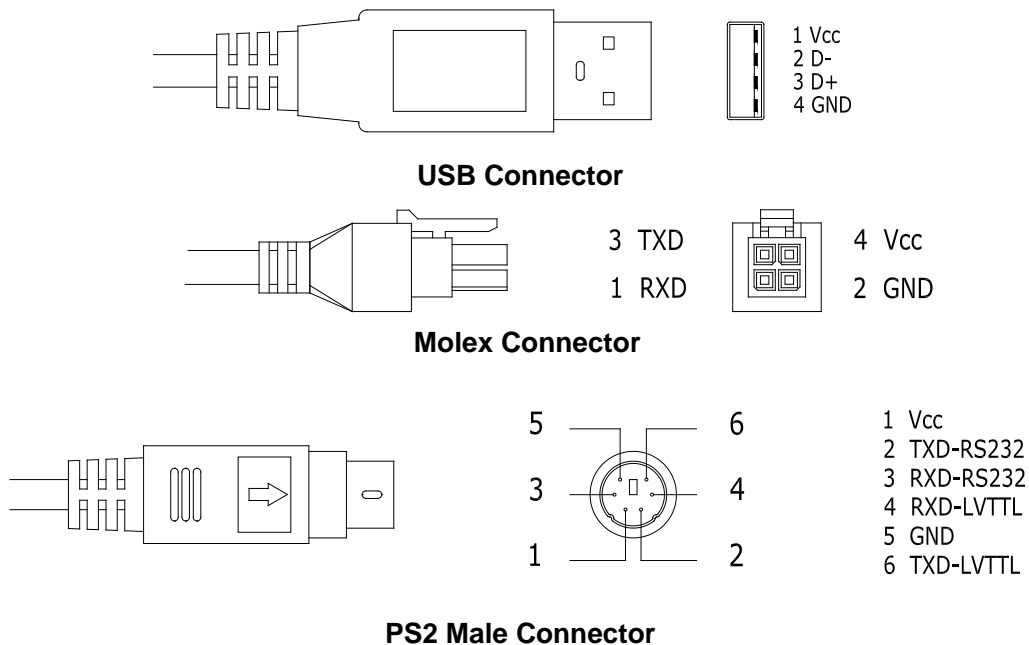

Figure 2: SKM55 Series Pin Package

Performance Specification

Parameter	Specification	
GPS receiver		
Receiver Type	L1 frequency band, C/A code, 22 Tracking / 66 Acquisition-Channel	
Sensitivity	Tracking	-165dBm
	Acquisition	-148dBm
Accuracy	Position	3.0m CEP50 without SA(Typical Open Sky)
	Velocity	0.1m/s without SA
	Timing (PPS)	60ns RMS
Acquisition Time	Cold Start	36s
	Warm Start	33s
	Hot Start	1s
	Re-Acquisition	<1s
Power Consumption	Tracking	<35mA @3.3V
	Acquisition	45mA @3.3V
	Sleep/Standby	TBD
Navigation Data Update Rate	1Hz	
Operational Limits	Altitude	Max 18,000m
	Velocity	Max 515m/s
	Acceleration	Less than 4g
Antenna Specifications		
Outline Dimension	25 x 25 x 4.0 mm	
Center Frequency	1575 ± 3 MHz	
Bandwidth	10 MHz min	
Impedance	50 Ω	
Axial Ratio	3 dB max	
Polarization	RHCP	
Mechanical requirements		
Dimension	46*45*15mm	
Weight	90g	
Power consumption		
VCC	5V ±5%	
Current	50mA(typical)	
Environment		
Operating temperature	40 ~ +85 °C (w/o backup battery)	
Storage temperature	40 ~ +125 °C	
Humidity	≧ 95%	

Hardware Interfaces Configuration

Power Supply: Regulated power for the SKM55 series is required. The input voltage Vcc should be 5V, current is no less than 150mA. Suitable decoupling must be provided by external decoupling circuitry(10uF and 1uF). It can reduce the Noise from power supply and increase power stability.

UART Ports: The SKM55 series supports one full duplex serial channels UART. The serial connections are at 2.85V LVTTTL logic levels, if need different voltage levels, use appropriate level shifters. the data format is however fixed: X, N, 8, 1, i.e. X baud rate, no parity,

eight data bits and one stop bit, no other data formats are supported, LSB is sent first. The modules default baud rate is set up 9600bps.

USB Ports: The SKM55 series uses single-chip USB to UART bridge, It is a USB 2.0 compliant full-speed device with integrated transceiver. Before using it, please install the appropriate driver.

RS232 Ports: The SKM55 series uses single-chip RS232 to UART bridge, It is 3V powered EIA/TIA-232 and V.28/V.24 communication interfaces with low power requirements.

Pin Description

Pin No.	Pin name	I/O	Description	Remark
UART Port (Molex Connector)				
1	RXD	I	TTL:VIH \geq 0.7 *VDD VIL \leq 0.3 *VDD	
2	GND	G	Power Ground	Reference Ground
3	TXD	O	TTL:VOH \geq 0.75 *VDD VOL \leq 0.25VDD	
4	VCC	P	Power Supply	VCC:5V
UART Port (PS2 Connector)				
1	VCC	P	Power Supply	VCC:5V
4	RXD	I	TTL:VIH \geq 0.7 *VDD VIL \leq 0.3 *VDD	
5	GND	G	Power Ground	Reference Ground
6	TXD	O	TTL:VOH \geq 0.75 *VDD VOL \leq 0.25VDD	
USB Port (USB Connector)				
1	VCC	P	USB Power Supply	
2	D-	I\O	Data-	
3	D+	I\O	Data+	
4	GND	G	USB Power Supply	Reference Ground
RS232 (Molex Connector)				
1	RXD	I	Data input(RS232 level)	
2	GND	G	Power Ground	Reference Ground
3	TXD	O	Data output(RS232 level)	
4	VCC	P	Power Supply	VCC:5V
RS232 (PS2 Connector)				
1	VCC	P	Power Supply	VCC:5V
2	TXD	O	Data output(RS232 level)	
3	RXD	I	Data input(RS232 level)	
5	GND	G	Power Ground	Reference Ground

Mechanical Specification

Molex Connector

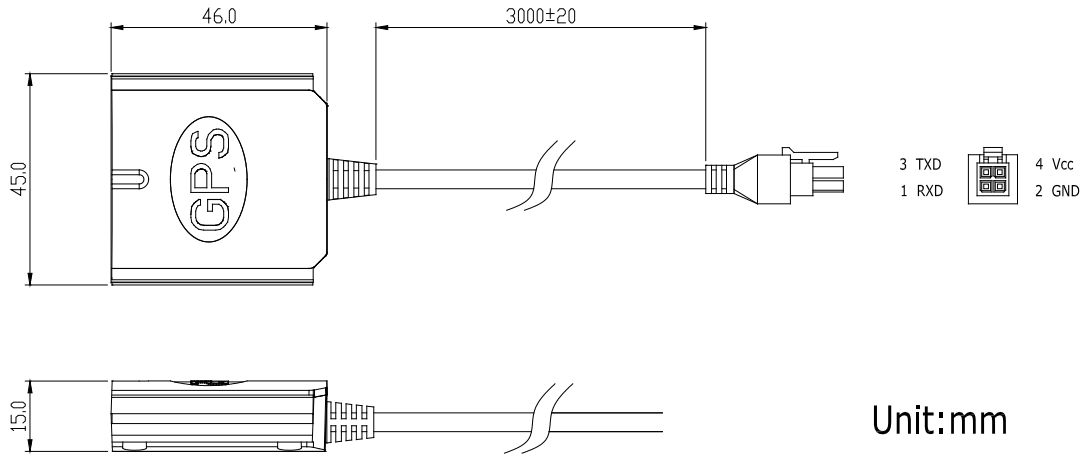

PS2 Connector

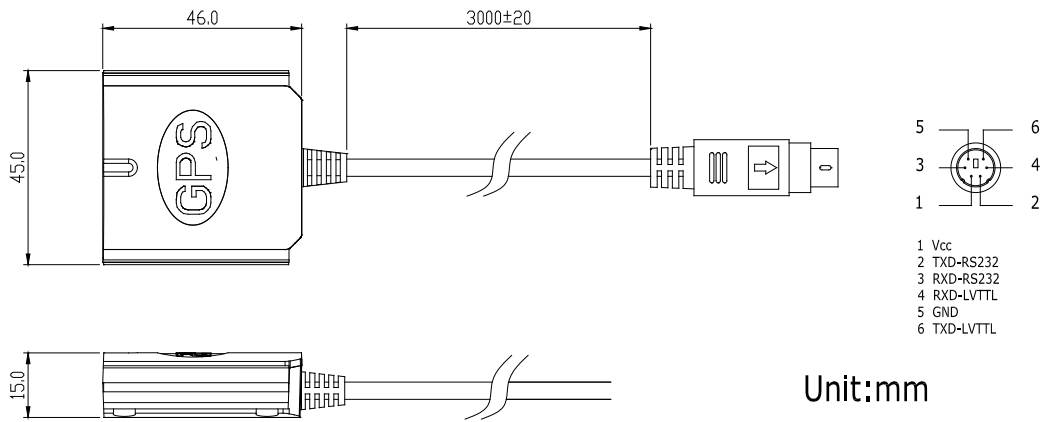

USB Connector

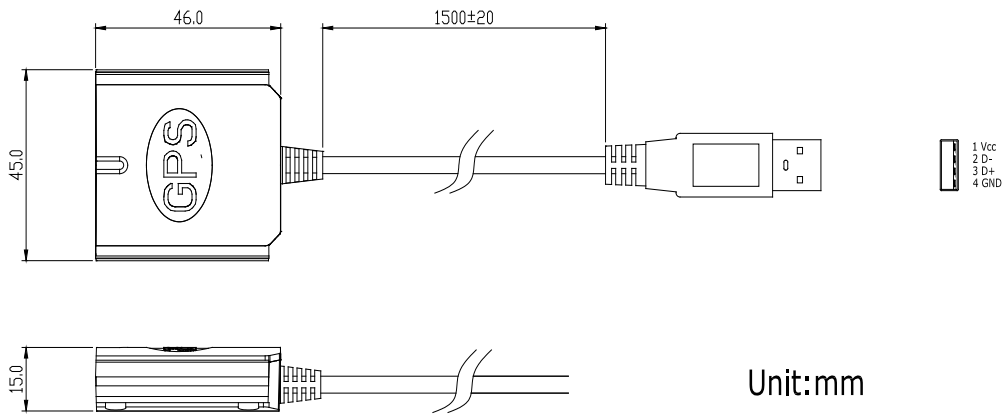

Ordering Information

	PS2	Molex (43025-0400)	USB
UART(TTL)	SKM55TP	SKM55TM	
RS232	SKM55RP	SKM55RM	
USB			SKM55U

User's Guide

Installing the USB Driver to you Laptop

Driver updates can be found at Silab's web-site:

<http://www.silabs.com/products/mcu/pages/usbtouartbridgevcpcdrivers.aspx> (<http://www.silabs.com>)

Com Port Verification

- Once your USB Driver has been installed, you will need to confirm which COM Port your PC has assigned to it in order to properly configure any software that will be utilizing the GPS data being received.
- Your USB GPS must be plugged into your USB port at this time.
- Using Window's Control Panel, select System > Hardware > Device Manager
- Then look under the heading of: PORTS (Com & LPT)
- There should be a listing for: CP210x USB to UART Bridge Controller (COM x)
("x" will actually be the number your PC has assigned the USB GPS receiver).
- Once you have identified the COM port number, any software that you utilize must be configured to read GPS data from this COM port.

We strongly suggest that you first test your USB GPS with the included GPS Info utility program to confirm that the GPS receiver is functioning properly on your PC and that you have successfully configured the right COM Port setting. Once this has been done, close the GPS Info program and start your application for COM port configuration. **NOTE:** By default, your PC will not allow you to run multiple applications from a single COM port. It is important that you close any previously opened GPS application before switching to another GPS application as the GPS receiver and data will not be found by the new program.

There are special utilities available to split data into multiple COM ports for use by more than one application simultaneously. (see: <http://franson.com/gpsgate/>)

Initialing your GPS receiver

Before using your USB GPS receiver for navigation (especially for the first time), the receiver must obtain a local GPS fix (coordinates) of the current position. To do this, take your laptop (with your USB driver and the mapping software loaded and configured) to an open area that has a clear view to the sky (such as a park or empty field). Start your software (or the included GPS Info utility program) and wait for initialization of the GPS to complete. This may take a few minutes depending on various factors such as the distance of the current coordinates from the last time the GPS receiver was activated, GPS signal strength and surrounding terrain (tall trees and buildings can block the satellite signals). In some cases initialization can take up to several minutes depending on the conditions .

Coordinates scrolling with zero's means that the port connection is complete, but the satellite data is not being

received yet (possibly still initializing or in a bad area for satellite reception).

Using/Testing your GPS Receiver

Once the USB GPS receiver's driver and your personal mapping software have been installed and configured properly, you can begin to use your navigation system by plugging the USB GPS into your laptop's USB port and launching your mapping software.

Software Protocol

NMEA 0183 Protocol

The NMEA protocol is an ASCII-based protocol, Records start with a \$ and with carriage return/line feed. GPS specific messages all start with \$GPxxx where xxx is a three-letter identifier of the message data that follows. NMEA messages have a checksum, which allows detection of corrupted data transfers.

The SkyNav SKM55 series supports the following NMEA-0183 messages: GGA, GLL, GSA, GSV, RMC, VTG, ZDA. The module default NMEA-0183 output is set up GGA, GSA, RMC, GSV, and default baud rate is set up 9600bps.

Table 1: NMEA-0183 Output Messages

NMEA Record	Description	Default
GGA	Global positioning system fixed data	Y
GLL	Geographic position—latitude/longitude	N
GSA	GNSS DOP and active satellites	Y
GSV	GNSS satellites in view	Y
RMC	Recommended minimum specific GNSS data	Y
VTG	Course over ground and ground speed	N
ZDA	Date and Time	N

GGA-Global Positioning System Fixed Data

This sentence contains the position, time and quality of the navigation fix.

See RMC for Fix Status, Fix Mode, Fix Date, Speed, and True Course.

See GSA for Fix Type, PDOP, and VDOP.

\$GPGGA,021514.000,2232.1799,N,11401.1823,E,1,6,1.25,84.0,M,-2.2,M,,*74

Table 2: GGA Data Format

Name	Example	Units	Description
Message ID	\$GPGGA		GGA protocol header
UTC Position	021514.000		hhmmss.sss
Latitude	2232.1799		ddmm.mmmm
N/S indicator	N		N=north or S=south
Longitude	11401.1823		dddmm.mmmm
E/W Indicator	E		E=east or W=west
Position Fix Indicator	1		See Table 2-1
Satellites Used	6		Range 0 to 12
HDOP	1.25		Horizontal Dilution of Precision

MSL Altitude	84.0	meters	Altitude (referenced to the Ellipsoid)
AltUnit	M	meters	Altitude Unit
GeoSep	-2.2	meters	Geoidal Separation
GeoSepUnit	M	meters	Geoidal Separation Unit
Age of Diff.Corr.	<Null>	second	Null fields when it is not Used
Diff.Ref.Station ID	<Null>		Null fields when it is not Used
Checksum	*74		
EOL	<CR> <LF>		End of message termination

Table 2-1: Position Fix Indicators

Value	Description
0	Fix not available or invalid
1	GPS SPS Mode, fix valid
2	Differential GPS, SPS Mode, fix valid
3	GPS PPS Mode, fix valid

GLL-Geographic Position – Latitude/Longitude

This sentence contains the fix latitude and longitude.

```
$GPGLL,2232.1799,N,11401.1824,E,021513.000,A,A*50
```

Table 3: GLL Data Format

Name	Example	Units	Description
Message ID	\$GPGLL		GLL protocol header
Latitude	2232.1799		ddmm.mmmm
N/S Indicator	N		N=north or S=south
Longitude	11401.1824		dddmm.mmmm
E/W Indicator	E		E=east or W=west
UTC Position	021513.000		hhmmss.sss
Fix Status	A		A=data valid or V=data not valid
Fix Mode	A		A=autonomous, N = No fix, D=DGPS, E=DR
Checksum	*50		
EOL	<CR> <LF>		End of message termination

GSA-GNSS DOP and Active Satellites

This sentence contains the mode of operation, type of fix, PRNs of the satellites used in the solution as well as PDOP, HDOP and VDOP.

```
$GPGSA,A,3,26,05,18,15,27,29,,,,,1.52,1.25,0.87*0F
```

Table 4: GSA Data Format

Name	Example	Units	Description
Message	\$GPGSA		GSA protocol header
Mode 1	A		See Table 4-2
Mode 2	3		See Table 4-1

ID of satellite used	26		Sv on Channel 1
ID of satellite used	05		Sv on Channel 2
...
ID of satellite used	<Null>		Sv on Channel 12 (Null fields when it is not Used)
PDOP	1.52		Position Dilution of Precision
HDOP	1.25		Horizontal Dilution of Precision
VDOP	0.87		Vertical Dilution of Precision
Checksum	*0F		
EOL	<CR> <LF>		End of message termination

Table 4-1: Mode 1

Value	Description
1	Fix not available
2	2D Fix
3	3D Fix

Table 4-2: Mode 2

Value	Description
M	Manual-forced to operate in 2D or 3D mode
A	Automatic-allowed to automatically switch 2D/3D

GSV-GNSS Satellites in View

This sentence contains the PRNs, azimuth, elevation, and signal strength of all satellites in view.

\$GPGSV,3,1,12,15,79,333,42,42,50,127,,29,45,263,44,02,36,124,30*7E

\$GPGSV,3,2,12,26,36,226,34,05,35,046,22,27,33,161,29,21,16,319,*7D

\$GPGSV,3,3,12,10,15,066,31,18,14,285,45,24,12,319,15,08,09,047,18*7E

Table 5: GGA Data Format

Name	Example	Units	Description
Message ID	\$GPGSV		GSV protocol header
Number of Message	3		Total number of GSV sentences (Range 1 to 3)
Message Number	1		Sentence number of the total (Range 1 to 3)
Satellites in View	12		Number of satellites in view
Satellite ID	15		Channel 1(Range 01 to 32)
Elevation	79	degrees	Channel 1(Range 00 to 90)
Azimuth	333	degrees	Channel 1(Range 000 to 359)
SNR(C/NO)	42	dB-Hz	Channel 1(Range 00 to 99, null when not tracking)
...			...
Satellite ID	02		Channel 4(Range 01 to 32)
Elevation	36	degrees	Channel 4(Range 00 to 90)
Azimuth	124	degrees	Channel 4(Range 000 to 359)
SNR(C/NO)	30	dB-Hz	Channel 4(Range 00 to 99, null when not tracking)
Checksum	*7E		

EOL	<CR> <LF>		End of message termination
-----	-----------	--	----------------------------

Depending on the number of satellites tracked multiple messages of GSV data may be required.

RMC-Recommended Minimum Specific GNSS Data

This sentence contains the recommended minimum fix information.

See GGA for Fix Quality, Sats Used, HDOP, Altitude, Geoidal Separation, and DGPS data.

See GSA for Fix Type, PDOP and VDOP.

\$GPRMC,023345.000,A,2232.1767,N,11401.1953,E,0.18,151.55,100410,,,A*6B

Table 6: RMC Data Format

Name	Example	Units	Description
Message ID	\$GPRMC		RMC protocol header
UTS Position	023345.000		hhmmss.sss
Status	A		A=data valid or V=data not valid
Latitude	2232.1767		ddmm.mmmm
N/S Indicator	N		N=north or S=south
Longitude	11401.1953		dddmm.mmmm
E/W Indicator	E		E=east or W=west
Speed Over Ground	0.18	Knots	
Course Over Ground	151.55	Degrees	True Course
Date(UTC)	100410		ddmmyy
Magnetic variation	<Null>	Degrees	Null fields when it is not Used
Magnetic Variation Direction	<Null>		E=east or W=west (Null fields when it is not Used)
Fix Mode	A		A=autonomous, N = No fix, D=DGPS, E=DR
Checksum	*6B		
EOL	<CR> <LF>		End of message termination

VTG-Course Over Ground and Ground Speed

This sentence contains the course and speed of the navigation solution.

\$GPVTG,148.81,T,,M,0.13,N,0.24,K,A*3D

Table 7: VTG Data Format

Name	Example	Units	Description
Message ID	\$GPVTG		VTG protocol header
Tcourse	148.81	Degrees	True Course
Reference	T		T = True
Mcourse	<Null>	Degrees	Magnetic Course (Null fields when it is not Used)
Reference	M		M = Magnetic (Null fields when it is not Used)
Speed over ground	0.13	Knots	Nautical Miles per Hour
Units	N		Knots
Speed over ground	0.24	Km/hr	in Kilometers per Hour
Units	K		Kilometer per hour

Mode	A		A=Autonomous, N=No fix, D=DGPS, E=DR
Checksum	*3D		
EOL	<CR> <LF>		End of message termination

ZDA-Date and Time

This sentence contains UTC date & time, and local time zone offset information.

\$GPZDA,023345.000,10,04,2010,,*50

Table 8: ZDA Data Format

Name	Example	Units	Description
Message ID	\$GPZDA		ZDA protocol header
UTC Time	023345.000		hhmmss.sss
Day	10		UTC time: day (01 ... 31) dd
Month	04		UTC time: month (01 ... 12) mm
Year	2010		UTC time: year (4 digit year) yyyy
local zone hours	<null>		Local Time Zone Offset Hours (Null fields when it is not Used)
local zone minutes	<null>		Local Time Zone Offset Minutes (Null fields when it is not Used)
Checksum	*50		
EOL	<CR> <LF>		End of message termination